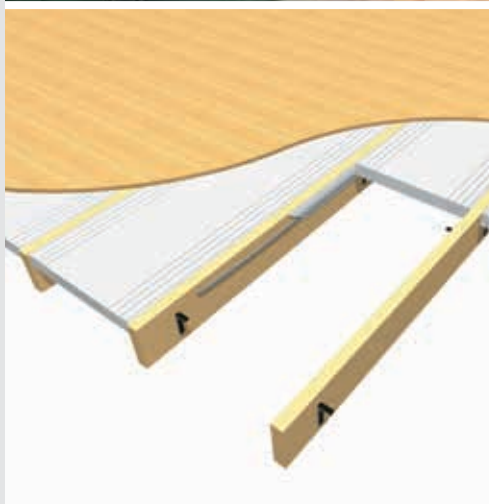


New Zealand Standard

# Energy efficiency – Installing bulk thermal insulation in residential buildings

Superseding NZS 4246:2006

NZS 4246:2016



## Single User PDF Terms & Conditions

You have material which is subject to strict conditions of use. Copyright in this material is owned by the New Zealand Standards Executive. Please read these terms and conditions carefully, as in addition to the usual range of civil remedies available to Standards New Zealand on behalf of the New Zealand Standards Executive for infringement of copyright, under New Zealand law every person who infringes copyright may be liable to a fine of up to \$10,000 for every infringing copy or imprisonment of up to 5 years, or a fine of up to \$150,000 or imprisonment not exceeding 5 years.

You have access to a single-user licence to read this non-revisable Adobe Acrobat PDF file and print out and retain ONE printed copy only.

We retain title and ownership of the copyright in this PDF file and the corresponding permitted printed copy at all times.

Under this license use of both the PDF file and the single permitted printed copy of this PDF file you may make are restricted to you. Under no circumstances are you permitted to save, sell, transfer, or copy this PDF file, the one permitted printed copy of this PDF file, or any part of either of them.

You undertake that you will not modify, adapt, translate, reverse engineer, decompile, disassemble or create derivative works based on any of the downloaded PDF file, nor will you merge it with any other software or document, even for internal use within your organization.

Under no circumstances may this PDF file be placed on a network of any sort without our express permission.

You are solely responsible for the selection of this PDF file and any advice or recommendation given by us about any aspect of this PDF file is intended for guidance only and is followed or acted upon entirely at your own risk.

We are not aware of any inherent risk of viruses in this PDF file at the time that it is accessed. We have exercised due diligence to ensure, so far as practicable, that this file does not contain such viruses.

No warranty of any form is given by us or by any party associated with us with regard to this PDF file, and you accept and acknowledge that we will not be liable in any way to you or any to other person in respect of any loss or damage however caused which may be suffered or incurred or which may arise directly or indirectly through any use of this PDF file.

Regardless of where you were when you received this PDF file you accept and acknowledge that to the fullest extent possible you submit to New Zealand law with regard to this licence and to your use of this PDF file.

Copyright Standards New  
Zealand

## COMMITTEE REPRESENTATION

This standard was prepared by the P4246 Committee. The membership of the committee was approved by the New Zealand Standards Approval Board and appointed by the New Zealand Standards Executive under the Standards and Accreditation Act 2015.

The committee consisted of representatives of the following nominating organisations:

BRANZ Ltd

Energy Efficiency and Conservation Authority

Insulation Association of New Zealand

Lighting Council New Zealand

Ministry of Business, Innovation and Employment – Building System Performance

National Association of Steel Framed Housing

New Zealand Certified Builders Association

Opus International Consultants

Registered Master Builders Association

WorkSafe New Zealand

## ACKNOWLEDGEMENTS

Standards New Zealand gratefully acknowledges the contribution of time and expertise from all those involved in developing this standard and, in particular, the following technical experts: Vanessa Lanegra, Tim Mahar, Mark Mischefski, Steve Morton, Nicholas Rowan, Gleb Speranski, Wade Maurice, Daniel Szczepanski, Bruce Vallance, Brian Usher, Bryan King, and Matthew Calder.

## COPYRIGHT

The New Zealand Standards Executive owns the copyright in this document. You may not reproduce any part of it without prior written permission of the New Zealand Standards Executive, unless your actions are covered by Part 3 of the Copyright Act 1994.

We will vigorously defend the copyright in this standard. Your unauthorised use may result in a fine of up to \$10,000 for every infringing copy or imprisonment of less than 5 years, or a fine of up to \$150,000 or imprisonment for less than 5 years. If the breach is serious, we may also seek additional damages from you as well as injunctive relief and/or an account of profits.

Published by Standards New Zealand, PO Box 1473, Wellington 6140.

Telephone: (03) 943 4259, Website: [www.standards.govt.nz](http://www.standards.govt.nz).

### AMENDMENTS

No.	Date of issue	Description	Entered by, and date

**NZS 4246:2016**

New Zealand Standard

**Energy efficiency –  
Installing bulk  
thermal insulation in  
residential buildings**

**Superseding NZS 4246:2006**

Copyright Standards  
Zealand

## NOTES

Copyright Standards New  
Zealand

# CONTENTS

Committee representation .....	IFC
Acknowledgements.....	IFC
Copyright.....	IFC
Referenced documents.....	vii
Latest revisions .....	ix
Review of standards.....	ix
Foreword .....	x
Outcome statement.....	x
<b>Section</b>	
1 INTRODUCTION .....	3
1.1 Scope.....	3
1.2 Interpretation.....	4
1.3 Definitions .....	5
2 SPECIAL CONSIDERATIONS.....	13
2.1 General.....	13
2.2 New Zealand Building Code compliance .....	13
2.3 Building consent .....	15
2.4 Effect of poor insulation installation on thermal performance.....	15
2.5 Effect of insulation compression on thermal performance.....	16
2.6 Storage and transport.....	16
2.7 Labelling on site .....	16
2.8 Health and safety .....	17
2.9 Managing electrical safety risks presented by foil insulation.....	17
2.10 Avoiding excessive insulation clearances .....	17
3 ELECTRICAL.....	21
3.1 General.....	21
3.2 Clearances for built-in appliances or enclosures containing electrical equipment .....	21
3.3 New buildings.....	21
3.4 Existing buildings.....	22
3.5 Avoiding contact between cables and polystyrene insulation.....	22
4 LIGHTING .....	25
4.1 General.....	25
4.2 Installing insulation near recessed luminaires.....	25
4.3 Installing insulation near surface-mounted luminaires.....	40
4.4 Installing insulation near independent controlgear in ceilings .....	43
4.5 Installing insulation near independent controlgear in subfloor spaces .....	45
4.6 Installing insulation near fan/heat/light units.....	46



5	WALLS .....	49
5.1	General.....	49
5.2	Special considerations .....	49
5.3	Timber/steel-framed walls with wall underlay .....	53
5.4	Timber/steel-framed walls without wall underlay .....	57
5.5	Loose-fill wall insulation.....	61
5.6	Masonry walls .....	63
6	CEILINGS AND ROOFS.....	67
6.1	General .....	67
6.2	Special considerations .....	67
6.3	Segments and blankets insulation – unlined ceilings.....	78
6.4	Segments and blankets insulation – lined ceilings.....	81
6.5	Rigid sheet insulation – unlined and lined ceilings.....	85
6.6	Loose-fill insulation – lined ceilings .....	86
7	UNDERFLOOR – SUSPENDED FRAMED FLOORS.....	91
7.1	General.....	91
7.2	Special considerations .....	91
7.3	Blanket underfloor insulation .....	93
7.4	Rigid sheet underfloor insulation.....	95
7.5	Semi-rigid underfloor insulation .....	97
8	ON-GROUND VAPOUR BARRIERS .....	103
8.1	Special considerations .....	103
8.2	Installing an on-ground vapour barrier .....	104
9	PIPE INSULATION AND CYLINDER WRAPS .....	109
9.1	General.....	109
9.2	Pipe insulation.....	109
9.3	Hot water cylinder wraps .....	110
10	CONCRETE SLAB-ON-GROUND INSULATION.....	115
10.1	Special considerations .....	115
10.2	Under-slab insulation.....	116
10.3	Slab perimeter insulation .....	117
<b>Appendix</b>		
A	Clearances (Normative) .....	121
B	Health and safety (Informative).....	126
C	Warning sign (Informative) .....	145
D	Climate zones (Informative) .....	146



**Figure**

1	Insulation installed with gaps, tucks and folds .....	15
2	Installing ceiling insulation around recessed luminaires of the type CA 80, CA 90, and CA 135 where the luminaire manufacturer's instructions are not known .....	36
3	Installing ceiling insulation around recessed luminaires of the type CA 80, CA 90, and CA 135 where the luminaire manufacturer's instructions are not known (ceilings with existing loose-fill insulation).....	36
4	Installing new loose-fill ceiling insulation around recessed luminaires of the type CA 80, CA 90, and CA 135 where the luminaire manufacturer's instructions are not known.....	37
5	Installing ceiling insulation around recessed luminaires of the type IC, IC-F, and IC-4 where the luminaire manufacturer's instructions are not known.....	37
6	Installing ceiling insulation around recessed luminaires of the type IC, IC-F, and IC-4 where the luminaire manufacturer's instructions are not known (ceilings with existing loose-fill insulation) .....	38
7	Installing new loose-fill ceiling insulation around recessed luminaires of the type IC, IC-F, and IC-4 where the luminaire manufacturer's instructions are not known .....	38
8	Installing ceiling insulation around recessed luminaires that are NOT of the type CA 80, CA 90, CA 135, IC, IC-F, or IC-4 where insulation is NOT secured in position or where insulation is loose-fill and where the luminaire manufacturer's instructions are not known .....	39
9	Installing ceiling insulation around recessed luminaires that are NOT of the type CA 80, CA 90, CA 135, IC, IC-F, or IC-4 where insulation is secured in position and where the luminaire manufacturer's instructions are not known.....	39
10	Example of underfloor insulation installed with clearance around a light fitting mounted to the bottom of a floor joist .....	42
11	Example of underfloor insulation installed with clearance around a light fitting mounted to the bottom of a floor joist .....	42
12	Example of underfloor insulation installed with clearance around a light fitting mounted to the side of a floor joist .....	42
13	Example of ceiling insulation installed with clearance around a light fitting mounted to the top of a ceiling joist .....	43
14	Example of ceiling insulation clearance around a recessed luminaire and independent controlgear not placed on top of insulation.....	44
15	Example of ceiling insulation clearance around independent controlgear not placed on top of insulation, where the manufacturer's instructions are not known .....	45
16	Insulation fitted into a steel-framed wall .....	55
17	Stapling blanket .....	55
18	Retrofitting wall underlay .....	57
19	Installing strapping horizontally .....	59
20	Steel-framed truss roof .....	70
21	Steel-framed skillion roof .....	70



22	Roof detail for a low-pitch roof .....	74
23	Skillion roof with metal tile cladding .....	74
24	Low-pitch roof with metal tiles .....	75
25	Profiled metal roof .....	75
26	Metal tile roof .....	76
27	Segments installed in a ceiling .....	79
28	Blanket in a ceiling secured with strapping .....	81
29	Friction-fitting insulation over joists .....	83
30	Installed underfloor blanket .....	95
31	Installation of underfloor rigid sheet floor insulation .....	96
32	Fitting semi-rigid sheets .....	98
33	On-ground vapour barrier folded up along foundation walls and overlapped along joins .....	105
34	On-ground vapour barrier folded up and taped around a pile .....	105
35	Insulated hot water cylinder .....	111
36	Under-slab insulation .....	115
37	Slab perimeter insulation .....	118
B1	Typical personal protective equipment (PPE) .....	131
C1	Warning sign .....	145
D1	New Zealand climate zones .....	146

**Table**

1	Installing ceiling insulation where recessed luminaires are already in place and where the luminaire manufacturer’s instructions are not known .....	27
A1	Clearances in the ceiling .....	121
A2	Clearances in the underfloor space .....	125
B1	Basic list of gear for insulation installers .....	129
B2	Installer’s personal protective equipment .....	129
B3	General installation health and safety risks .....	132
B4	Ceiling installation health and safety hazards .....	137
B5	Underfloor installation health and safety hazards .....	139
B6	Installing underfloor insulation with power ON .....	142
B7	Installing underfloor insulation with power OFF .....	142
B8	Hot water cylinder health and safety precautions .....	144

## REFERENCED DOCUMENTS

Reference is made in this document to the following:

### New Zealand standards

NZS 3604:2011	Timber-framed buildings
NZS 4218:2009	Energy efficiency – Housing and small buildings
NZS 4305:1996	Energy efficiency – Domestic type hot water systems

### Joint Australian/New Zealand standards

AS/NZS 1715:2009	Selection, use and maintenance of respiratory protective equipment
AS/NZS 1716:2012	Respiratory protective devices
AS/NZS 2918:2001	Domestic solid fuel burning appliances – Installation
AS/NZS 3760:2010	In-service safety inspection and testing of electrical equipment
AS/NZS 4859:- - - -	Materials for the thermal insulation of buildings
Part 1:2002	General criteria and technical provisions
AS/NZS 5110:2011	Recessed luminaire barriers
AS/NZS 5601:- - - -	Gas installations
Part.1:2010	General installations
AS/NZS 60598:- - - -	Luminaires
Part.2.2:2001	Particular requirements – Recessed luminaires (Incorporating New Zealand-only Amendment A)
AS/NZS 60598:- - - -	Luminaires
Part 2.2:2016	Particular requirements – Recessed luminaires
AS/NZS 60695:- - - -	Fire hazard testing
Part 11.5:2005	Test flames – Needle-flame test method – Apparatus, confirmatory test arrangement and guidance

### International standards

ISO 5660:- - - -	Reaction-to-fire tests – Heat release, smoke production and mass loss rate
Part 1:2002	Heat release rate (cone calorimeter method)

### Australian standards

AS 1366 (series)	Rigid cellular plastics sheets for thermal insulation
AS 1691:1985	Domestic oil-fired appliances – Installation
AS 1530:- - - -	Methods for fire tests on building materials, components and structures
Part 1:1994	Combustibility test for materials

### Other publications

NZCEP 55:2016	New Zealand electrical code of practice for managing electrical risks associated with electrically conductive thermal insulation (Retrieved on 12 August 2016 from <a href="http://www.energysafety.govt.nz/documents/legislation-policy/electricity-act-regulations-codes/standards-and-codes-of-practice/nzcep-55-july-2016.pdf">www.energysafety.govt.nz/documents/legislation-policy/electricity-act-regulations-codes/standards-and-codes-of-practice/nzcep-55-july-2016.pdf</a> )
---------------	---

### New Zealand legislation

Building Act 2004
Building Regulations 1992 (New Zealand Building Code (NZBC))
Electricity Act 1992
Electricity (Safety) Regulations 2010
Health and Safety at Work Act 2015
Health and Safety at Work (Asbestos) Regulations 2016
Residential Tenancies (Smoke Alarms and Insulation) Regulations 2016

### Websites

<a href="http://www.business.govt.nz/worksafe/hswa">www.business.govt.nz/worksafe/hswa</a>
<a href="http://www.business.govt.nz/worksafe/information-guidance/guidance-by-hazard-type/asbestos/working-with-asbestos/tools-and-resources">www.business.govt.nz/worksafe/information-guidance/guidance-by-hazard-type/asbestos/working-with-asbestos/tools-and-resources</a>
<a href="http://www.branz.co.nz/appraisals">www.branz.co.nz/appraisals</a>
<a href="http://www.ewrb.govt.nz">www.ewrb.govt.nz</a>
<a href="http://www.iaonz.co.nz">www.iaonz.co.nz</a>
<a href="http://www.legislation.govt.nz">www.legislation.govt.nz</a>
<a href="http://www.lightingcouncil.org.nz">www.lightingcouncil.org.nz</a>

## LATEST REVISIONS

The users of this standard should ensure that their copies of the above-mentioned New Zealand standards are the latest revisions. Amendments to referenced New Zealand and joint Australian/New Zealand standards can be found on [www.standards.govt.nz](http://www.standards.govt.nz).

## REVIEW OF STANDARDS

Suggestions for improvement of this standard will be welcomed. They should be sent to the New Zealand Standards Executive, Standards New Zealand, PO Box 1473, Wellington 6140.

Copyright Standards New Zealand

## FOREWORD

New Zealanders are aware of the critical role thermal insulation plays in creating living environments that are healthy and comfortable for occupants and that are affordable to heat.

Energy efficient building design, and the use of quality insulation products are important, but thermal insulation can only perform effectively, and thereby meet any relevant building code and other regulatory requirements or building specifications, if it is installed correctly. Incorrectly installing insulation can compromise the durability of the building and put the health and safety of installers and occupants of the building at serious risk.

This standard supports the installation of insulation by professional and DIY installers to ensure good thermal performance without compromising durability or health and safety. On-ground vapour barriers have been included as a means of protecting and enhancing the performance of insulation products, even though they are not, in themselves, insulation products.

The installation of foil insulation continues to be excluded from the scope of this revised standard and the installation or repair of foil insulation in residential buildings with existing electrical installations is now banned under the Building Act, section 26. The retrofitting of foil insulation in rental properties is also not permitted under the Residential Tenancies (Smoke Alarms and Insulation) Regulations.

Previous versions of this standard have set the standard for installing insulation and have contributed to the success of the New Zealand Government's insulation retrofit programmes for residential buildings. This updated version of the standard also provides recommendations for new construction where poor insulation installation is still all too common.

This revised 2016 standard has been restructured for improved readability and has been updated and extended to provide guidance on installing insulation in steel-framed constructions and for concrete slabs on ground. Additional diagrams, photos, and figures have been included for illustrative purposes.

This standard is presented in sections and has been developed with the intention that each section can be read as a stand-alone set of guidance principles, with reference to other sections as required. As such, there is some repetition between the sections to ensure that no details are overlooked.

## OUTCOME STATEMENT

NZS 4246:2016 *Energy efficiency – Installing bulk thermal insulation in residential buildings* provides guidance for the correct installation of quality insulation products by installers and consumers to achieve the intended thermal performance in buildings without compromising the durability and safety of insulation or building elements and the health and safety of installers and building occupants.

# SECTION 1

## INTRODUCTION

- 1.1 **Scope**
- 1.2 **Interpretation**
- 1.3 **Definitions**

Copyright Standards New Zealand

Copyright Standards New  
Zealand



New Zealand Standard

# Energy efficiency – Installing bulk thermal insulation in residential buildings

## 1 INTRODUCTION

### 1.1 Scope

#### 1.1.1 Inclusions

This standard outlines methods of installing insulation products in common residential light-timber and steel-framed construction types. Information on the safe installation (clearances, health and safety) of insulating materials is appended.

The detail in the standard is based on residential-type construction, but the methods may be appropriate to other constructions.

The standard covers both the installing of insulation in new buildings during construction and the retrofitting of insulation in existing buildings.

On-ground vapour barriers have been included although they are not, in themselves, insulation products, because reducing the migration of water vapour into the subfloor space helps keep indoor air drier, reducing condensation and the growth of mould and mildew, which helps maintain a healthy living environment in buildings.

The following product types and applications are covered by this standard:

- (a) Loose-fill product (such as wool, mineral wool, or cellulose fibre) for insulating walls and ceilings;
- (b) Segment and blanket products (such as polyester, wool or mineral wool) for insulating walls, ceilings, and floors;
- (c) Rigid sheet insulation products (such as expanded or extruded polystyrene (EPS or XPS) and polyisocyanurate (PIR) for insulating walls, ceilings, and floors;
- (d) Semi-rigid insulation (such as wool, mineral wool, polyester) for insulating walls, ceilings, and floors;
- (e) Pipe insulation (such as pre-formed tubular foam);
- (f) Hot water cylinder wraps (such as wool, mineral wool, or polyester blanket with cloth or foil-backing);
- (g) On-ground vapour barriers.

Thermal breaks for steel-framed constructions are referenced in this standard but not covered in detail. ➤

Included in this standard is advice about the safe and effective installation of insulation around recessed luminaires. This information is limited to situations where the luminaires are already in place before the insulation is installed and therefore does not provide guidance to registered electricians when installing or replacing luminaires in ceilings that are already insulated.

### 1.1.2 Exclusions

This standard excludes installation of:

- (a) Structural elements of buildings that provide inherent thermal resistance;
- (b) Insulation in buildings with specific design, including freezers or cool stores;
- (c) Insulation in buildings where insulation is part of the cladding material, such as exterior insulation and finish systems (EIFS);
- (d) Insulation for purposes other than for thermal benefit, such as acoustic;
- (e) Vapour barriers where these may be required in building elements around areas such as spa pools, swimming pools, or mountain lodges;
- (f) Passive thermal design;
- (g) Pre-assembled insulating systems;
- (h) Double glazing (for further information on glazing and R-values, refer to NZS 4218);
- (i) Expanding *in situ* foams;
- (j) Radiant barriers in walls and ceilings;
- (k) Foil insulation;
- (l) Insulation in ventilation cavities of walls, including brick veneer cavities;
- (m) Insulation in the cavity of double brick walls.

## 1.2 Interpretation

Clauses in this standard prescribe practices that are essential for compliance with this standard, except where:

- (a) The word 'should' refers to practices that are advised or recommended;
- (b) Clauses are prefixed 'C' and printed in italic type. These are intended as comments on the corresponding clauses. They are not to be taken as the only or complete interpretation. The standard can be complied with if the comment is ignored.

Clauses prefixed by 'NOTE' are intended as comments on the corresponding essential clauses. They are not to be taken as the only or complete interpretation of the corresponding clause nor should they be used for determining in any way the essential requirements of compliance within this standard.

The terms 'normative' and 'informative' have been used in this standard to define the application of the appendix to which they apply. A 'normative' appendix is an integral part of a standard while an 'informative' appendix is only for information and guidance.

### 1.3 Definitions

For the purposes of NZS 4246, the following definitions shall apply. The plural of a defined term shall have the same meaning as the singular and vice versa.

<b>Anti-ponding board</b>	Plywood or timber fixed at the bottom of the roof slope, which prevents the bottom portion of the roof underlay sagging and ensures that any water that may get onto the underlay can drain into a gutter
<b>Blanket</b>	Non-rigid insulation product provided in a roll. The roll may be available in varying widths, lengths, and thickness
<b>Building consent authority</b>	Building consent authorities are councils, regional authorities, or private organisations registered under section 273 of the Building Act. Only a building consent authority can issue a building consent
<b>Conditioned spaces</b>	That part of a building within the building's thermal envelope, including habitable areas that may be directly or indirectly heated or cooled for occupant comfort
<b>Combustible</b>	Materials classified as combustible when tested to AS 1530.1
<b>Enclosed perimeter foundation</b>	An enclosed foundation wall that is continuous around the perimeter of a house. This can be made from materials such as concrete, fibre cement board, weatherboard, or other such material. Walls shall go to ground level with no gaps other than access-point and ventilation vents as typically found in concrete perimeter foundations
<b>Friction-fit</b>	Friction-fit means that the insulation is held in place by friction after insulation is pushed into place, without additional means of fastening
<b>Foamed plastics</b>	Foamed plastic polymeric materials of low density (typically less than 100 kg/m <sup>3</sup> ), classified as cellular polymers, which are manufactured by creating a multitude of fine voids (typically 90% to 98%) distributed more or less uniformly throughout the product. Examples of foamed plastics are expanded or extruded polystyrene foams, urea formaldehyde foams, and polyurethane foams



<b>Foil insulation</b>	Insulation that consists of a thin layer of heat-reflecting metallic foil (usually aluminium). It is most commonly supplied in flexible sheets or blanket form and may be attached to other flexible insulating materials such as wool or fibreglass
<b>Guard</b>	A component fit for purpose to provide adequate separation from combustible building elements, insulation, and debris to reduce the fire risk caused by recessed luminaires and other heat-generating equipment. A guard is rigid and has means by which it can be attached to the building element for which it is designed. A guard has a clearance between its interior surface and the recessed luminaire or other heat-generating equipment around which it is installed that is no less than any clearance required by this standard between insulation and the recessed luminaire or other heat-generating equipment around which it is installed. A guard's top surface area is at least 80% open with respect to the footprint of the recessed luminaire or other heat-generating equipment around which it is installed. A guard is made of fire-retarding, electrically non-conductive materials (except for any fixings or fasteners) and can withstand a minimum long-term surface operating temperature of 90°C
<b>Habitable area</b>	An area used for activities normally associated with domestic living, including kitchen, lounge, dining room, bedrooms, hallways, bathrooms, laundry, water closet, pantry, walk-in wardrobe, corridor, hallway, lobby, clothes-drying room, or garage
<b>Hot water cylinder wraps</b>	Comprised of a blanket insulation product with a cotton or foil exterior
<b>Independent controlgear</b>	Equipment that is required in order to operate another device such as transformers, ballasts, or drivers for luminaires. This is separated from the equipment for which it is required.
<b><i>In situ</i> foams</b>	Formed-in-place insulation made from foam that expands in place. An example is sprayed foam
<b>Insulation material</b>	Material used to increase the thermal resistance of building elements

<b>Insulation product</b>	An insulation material commodity that is produced by manufacture or by a natural process and is offered for sale
<b>Lampholder</b>	A device that holds a lamp in position, usually by having a cap inserted in it, in which case it also provides the means of connecting the lamp to the electric supply
<b>Loose-fill</b>	Insulation that is in the form of small particles or fibres that are blown into place
<b>Luminaire (lighting fitting)</b>	A complete lighting assembly intended to distribute, filter, or transform the light from one or more lamps, together with such components as independent or integral controlgear, shapes, diffusers, reflectors, and accessories. Such an assembly includes the means of connection to supply circuit wiring, internal and interconnecting wiring, and any associated housings. A lampholder that is not incorporated in an assembly is not regarded as a luminaire.
<b>Mechanical vent</b>	A venting device that draws air from or to the interior by means of an electrical motor
<b>Mineral wool</b>	Fibrous insulation made from inorganic oxides or minerals, rock slag, or glass. The most commonly used mineral wool insulations are glass wool and rock wool
<b>Moisture</b>	Water diffused as vapour or condensed on or in objects
<b>Non-combustible</b>	A material that complies with the respective requirements and definitions in AS 1530.1 as verified by an accredited testing agency
<b>NZBC</b>	New Zealand Building Code (Schedule 1 of the Building Regulations)
<b>Passive vent</b>	A vent generally found in ceilings or subfloor spaces. It consists of either a section of preset drill holes or a hole covered by fine mesh. Such vents are typically found in bathrooms, kitchens, laundries, and around the perimeter foundation
<b>Pipe insulation</b>	Insulation products designed for insulating pipes
<b>Pitched roof</b>	Roof constructed with a space between the rafters and ceiling joists or truss chords where the ceiling and the roof are not parallel



<b>R-value</b>	The value of thermal resistance of a building element (such as wall, floor, or roof), that is, the sum of the surface resistances on each side of a building element and the thermal resistances of each component of the building element including any cavities in the element. It is determined by calculation or by measuring the temperature difference between the internal air on one side and the external air on the other side of a building component, when there is unit heat flow in unit time through unit area using internal and external conditions considered as typical for buildings (m <sup>2</sup> .°C/W)
<b>Recessed luminaire</b>	A light fitting intended by the manufacturer to be fully or partly recessed into a mounting surface such as a floor, wall, or ceiling, commonly known as a downlight
<b>Recessed luminaire barrier</b>	A product tested and classified in compliance with AS/NZS 5110, including all New Zealand only compliance criteria, as being suitable for the luminaire type or types and installation conditions. A recessed luminaire barrier is used to provide adequate separation from combustible building elements, insulation, and debris to reduce the fire risk caused by recessed luminaires
<b>Registered electrician</b>	Electrician or electrical inspector registered and licensed by the Electrical Workers Registration Board to carry out prescribed electrical work in an installation.  NOTE – To check if an electrical worker is licensed search the public register of electrical workers online at <a href="http://www.ewrb.govt.nz">www.ewrb.govt.nz</a> or alternatively contact the Electrical Workers Registration Board on 0800 661 000
<b>Rigid sheet insulation</b>	Insulation in the form of a rigid board that cannot be folded or bent but shall be cut to fit into place. These are usually of rigid cellular plastic, for example polystyrene insulation products
<b>Roofing material</b>	Includes roofing underlay such as black tar paper and roofing only, for example, iron and tiles. Does not include any timber to which the roof is attached (such as rafters), anti-ponding boards, or any wire mesh supporting the roof underlay

<b>Segments</b>	Also known as pieces or pre-formed shapes. Insulation product pre-cut to small standard units. The pre-formed shape may be available in varying sizes and thicknesses
<b>Semi-rigid insulation</b>	Insulation that is self-supporting on a vertical or horizontal plane, but can be folded when required. It is a firm but flexible insulation product of a medium to high density
<b>Skillion roof</b>	A pitched roof, which may be either flat or low pitch (typically less than 12 degrees), where the ceiling lining is parallel and close to the roof cladding. May also be a normal or steep pitch typically called a chapel ceiling. The roof may consist of more than one roof plane. The rafters may or may not be exposed below the ceiling
<b>Strongback</b>	A structural timber framing member installed over the ceiling joists in the ceiling space to provide support to the joists from above
<b>Surface-mounted luminaire</b>	Any luminaire that is mounted to a surface of wall, ceiling, or underfloor which does not protrude through any part of the lining
<b>Thermal break</b>	Material placed on the outdoor side of steel framing to reduce the conduction of heat through the framing
<b>Thermal envelope</b>	The roof or ceiling, walls, glazing, skylights, doors, and floor construction between conditioned spaces and unconditioned spaces/outside
<b>Thermal resistance (R)</b>	A measure of resistance to the flow of heat. It can be determined by measuring the temperature difference that is maintained between surfaces or planes when there is constant heat flow between them in unit time through unit area ( $\text{m}^2 \cdot ^\circ\text{C}/\text{W}$ )
<b>Unconditioned spaces</b>	That part of a building that would not normally be conditioned for occupant comfort (for example, garage, conservatory)
<b>Wool</b>	Wool derived from the fleece of a sheep, or animal with similar fibres

## NOTES

Copyright Standards New  
Zealand



## SECTION 2

# SPECIAL CONSIDERATIONS

- 2.1 General
- 2.2 New Zealand Building Code compliance
- 2.3 Building consent
- 2.4 Effect of poor insulation installation on thermal performance
- 2.5 Effect of insulation compression on thermal performance
- 2.6 Storage and transport
- 2.7 Labelling on site
- 2.8 Health and safety
- 2.9 Managing electrical safety risks presented by foil insulation
- 2.10 Avoiding excessive insulation clearances

Copyright Standards New  
Zealand

## 2 SPECIAL CONSIDERATIONS

### 2.1 General

This section describes some areas where special care shall be taken when handling and installing insulation.

### 2.2 New Zealand Building Code compliance

#### 2.2.1 All work shall comply with NZBC

All construction work on houses, including installing or retrofitting insulation, shall comply with the New Zealand Building Code (NZBC).

#### 2.2.2 New buildings

NZBC requirements for energy efficiency (Clause H1) and internal moisture (Clause E3) generally require thermal insulation to be used for the building to comply. When installed, insulation shall also comply with NZBC requirements for durability, protection from fire, moisture transfer, moisture accumulation, and electrical safety.

#### 2.2.3 Existing buildings

Retrofitting insulation into existing houses has different compliance requirements to new houses.

NZBC requirements for durability, protection from fire, moisture transfer, moisture accumulation, and electrical safety shall be complied with when retrofitting insulation. NZBC requirements for energy efficiency and internal moisture do not apply to retrofitting insulation in existing houses, which means there is no minimum level of insulation that shall be retrofitted. However, given the time and effort to retrofit insulation it is recommended that as much insulation as practicable be installed.

If existing insulation is removed, then it shall be replaced with insulation of equal or better performance (that is, equal or higher R-value).

#### **C2.2.3**

*The Residential Tenancies (Smoke Alarms and Insulation) Regulations require minimum levels of ceiling and underfloor insulation to be present in rental properties, which may require insulation to be retrofitted or existing insulation to be upgraded. The Regulations also specify the minimum R-values for the insulation products being installed.*

**2.2.4 Durability of insulation**

Insulation shall maintain its claimed performance for periods of time that are prescribed in the Acceptable Solution for NZBC Clause B2 Durability, B2/AS1. The amount of time depends on the function of the product, its accessibility, ease of replacement, and detection of failure, but is typically 50 years.

Product shall be installed in such a way that the claimed thermal performance will still be achieved at the point when it is expected to be serviced. In practice this would require some products to have an initial thermal performance above the claimed value to allow for settling.

NOTE – The ingress of moisture, settlement, air movement, and slight movement of materials encasing the insulation are some of the causes of deterioration of insulation products or their installation.

**2.2.5 Protection from fire**

Insulation shall not be installed so that it creates a fire risk.

Minimum clearances shall be maintained between insulation and appliances and fixtures that are hot, for example space heating, hot water heaters, lighting, chimneys, and flues. Safe minimum clearances are provided in Appendix A of this standard and in NZBC Acceptable Solution C/AS1 for NZBC Clauses C1 – C6 and the associated standards.

Combustible insulation shall not be left exposed in escape routes from bedrooms (escape routes are areas of a house that people will travel through when escaping a fire). If combustible insulation is used, it shall be installed behind a non-combustible lining, such as plasterboard. Detailed requirements and definitions for combustible insulation are given in Acceptable Solution C/AS1 for NZBC Clauses C1 – C6.

**2.2.6 Electrical safety**

Insulation shall not be installed so that it compromises electrical safety. Sections 3 and 4 describe clearances and procedures that shall be followed when insulation is installed (or retrofitted) around light fittings, electrical appliances, and electrical cabling.

**2.2.7 Moisture transfer and accumulation**

Insulation shall not be installed in ways that allow moisture to transfer through or to accumulate in wall, roof, or floor cavities in sufficient quantities to cause condensation, fungal growth, or damage to framing, claddings, or linings.

**2.2.8 Ban on installing foil insulation in residential buildings with existing electrical installations**

Installing or repairing foil insulation in residential buildings with existing electrical installations is banned under the Building Act. Retrofitting foil insulation in rental properties is also prohibited under the Residential Tenancies (Smoke Alarms and Insulation) Regulations.

## 2.3 Building consent

New house construction, including the installation of insulation, requires a building consent.

A building consent is not required for retrofitting insulation into the roof or underfloor of existing houses, but is required for retrofitting insulation into the external walls of houses. Check with the local building consent authority as an exemption may apply.

## 2.4 Effect of poor insulation installation on thermal performance

Insulation shall be handled and installed correctly so building elements achieve the R-values required by any relevant regulations or building design specifications.

Poor installation, such as folds, tucking in, and gaps, will reduce the effectiveness of insulation; gaps as small as a few millimetres around the edges of insulation can halve the overall thermal resistance (see Figure 1).

### C2.4

*In ceilings, gaps around the edges of insulation reduce the effective R-value of the insulation by approximately 3% for every 1 mm gap. For example, with a gap of 16 mm around the edge, the effective R-value of the insulation is about half the nominal R-value ( $16 \times 3\% = 48\%$ ).*

*In walls, the occurrence of face gaps (between the insulation and cladding and lining materials) in conjunction with edge gaps is even more detrimental as the thermal performance of the insulation is likely to be completely negated. Face gaps occur if the thickness of the insulation is less than the depth of the frame cavity or if in situ foam shrinks.*

*In walls, settlement of insulation results in a gap on the top edge only and reduces the R-value of the insulation by about 1% for every 5 mm of settlement.*



Figure 1 – Insulation installed with gaps, tucks and folds

## 2.5 Effect of insulation compression on thermal performance

The ability of a product to reach its nominal thickness is important to the product achieving the declared product R-value. It is important to product performance that when installing any given product, the nominal thickness is known and achieved.

Insulation products shall be installed in a cavity at least sufficiently large enough to accommodate the nominal thickness plus any required clearance. Compressing the insulation into a cavity smaller than the insulation's thickness will reduce its actual delivered R-value in almost direct relation to the amount compressed.

NOTE – When a product that is R 2.0 at 100 mm is compressed down to 80 mm the result is an R-value of approximately 80% of 2.0, or 1.6.

## 2.6 Storage and transport

All insulation products shall be protected from the weather until use and be undamaged and dry when installed.

Follow the manufacturer's instructions on handling insulation products during storage and transport to avoid product damage.

Some products may need to be top stowed only and shall not have products loaded on top of them on site either temporarily or permanently.

## 2.7 Labelling on site

Provide labels with insulation product and installer information to the building owner or other authorised person. If practicable this should be done by permanently fixing these labels on site where they can be easily found for future inspection. Examples include the hot water cupboard, a roof rafter or truss, or a floor joist by an access hatch.

The insulation product label provided shall be in accordance with AS/NZS 4859.1 and contain the following information:

- (a) Product name;
- (b) Description of contents;
- (c) Name and address of manufacturer;
- (d) Declared R-value;
- (e) Nominal coverage (area per unit mass);
- (f) Nominal thickness (mm); and
- (g) Nominal net weight of contents or supplied quantity (kg).

The label with installer information shall contain the following information:

- (h) Date of installation;
- (i) Name, and if applicable company name, and address of installer.

Both insulation product and installer information may be provided on the same label.

**C2.7**

*Labels made from paper or cardboard can deteriorate rapidly when fixed in subfloor spaces. Fixing such labels in an alternative location, for example in a hot water cupboard, is preferable.*

**2.8 Health and safety**

For information on the health and safety aspects of installing insulation see Appendix B and refer to the manufacturer's instructions.

**2.9 Managing electrical safety risks presented by foil insulation**

In buildings with existing foil insulation follow NZECP 55.

**C2.9**

*Exercise extreme caution when working with and around existing foil insulation as it may be or may become electrically live, for example when its mechanical fixings pierce electrical cables. NZECP 55 is a code of practice made under the Electricity Act. It addresses electrical safety risks of removing, altering, repairing or working in the presence of installed foil insulation. Also see Appendix B of this standard for further health and safety information.*

**2.10 Avoiding excessive insulation clearances**

Where the manufacturer's instructions or this standard require minimum clearances between the insulation and other building elements or equipment, do not exceed these minimum clearances by more than 50 mm wherever practicable.

## NOTES

Copyright Standards New  
Zealand



## SECTION 3

# ELECTRICAL

- 3.1 General
- 3.2 Clearances for built-in appliances or enclosures containing electrical equipment
- 3.3 New buildings
- 3.4 Existing buildings
- 3.5 Avoiding contact between cables and polystyrene insulation

Copyright Standards New Zealand

Copyright Standards New  
Zealand

## 3 ELECTRICAL

### 3.1 General

This section describes some areas where special care shall be taken when installing insulation near cables and electrical equipment. Information specific to luminaires and related equipment can be found in section 4.

When installing insulation care shall be taken to avoid damaging cables and electrical equipment. Careless work near cables and electrical equipment can result in serious injury to the insulation installer or building occupant, or death. See Appendix B, the Electricity (Safety) Regulations, and the manufacturer's instructions for important health and safety information. Refer to a registered electrician if further guidance is required.

### 3.2 Clearances for built-in appliances or enclosures containing electrical equipment

If built-in appliances or enclosures containing electrical equipment are present in the space to be insulated, insulation shall not be placed closer than 50 mm around the appliance or enclosure unless the manufacturer's instructions are known and allow insulation to touch the appliance or enclosure.

Where the manufacturer's instructions are known these shall be followed.

If unsure refer to a registered electrician for further guidance.

NOTE –

- (1) Built-in appliances include any mains-powered electrical equipment including heaters, ovens and stoves, garage door openers, alarm control boxes, and the parts of mechanical ventilation systems that contain electrical equipment.
- (2) Built-in appliances or enclosures containing electrical equipment do not include cables, cable junction boxes, light switches, or power sockets.
- (3) For clearances around luminaires and fan/heat/light units see section 4.
- (4) For clearances around unducted mechanical fan units see 6.2.12.

### 3.3 New buildings

Cables and electrical equipment penetrating or located inside the insulation layer can affect the ability to install insulation effectively and thereby compromise compliance with the NZBC, Electricity (Safety) Regulations, and building design specifications.

Wherever practicable, the building design should locate cables and equipment outside the thermal insulation layer.

The installation of electrical equipment and insulation should be scheduled in a way that minimises the risk of damage to prior work. For the best thermal performance, insulation should be installed after all cables and equipment have already been fitted in wall, ceiling, or floor cavities.

Where electrical equipment is installed after insulation has been fitted, the integrity of the insulation should not be compromised by the electrical installation.

Following completion of the electrical work, the person responsible for the project shall verify, or obtain verification, that the integrity of the insulation has not been compromised.

### 3.4 Existing buildings

Care shall be taken to avoid damaging cables and equipment while retrofitting insulation in existing buildings.

Cables and equipment, such as electrical insulation on some of the older type electrical cabling, can be aged and brittle. Therefore insulation installers shall avoid pulling, standing on, putting pressure on, or applying force to cables and equipment, which may damage them.

Any damaged cables or equipment shall be repaired or replaced by a registered electrician before insulation installation proceeds.

Refer to a registered electrician for further guidance.

### 3.5 Avoiding contact between cables and polystyrene insulation

When installing polystyrene insulation in areas around PVC-coated cables, ensure there is no contact between the polystyrene and the PVC. Methods of avoiding contact include:

- (a) Installing cables in a conduit;
- (b) Using polyethylene or polypropylene tape between the PVC and the polystyrene;
- (c) Using cables with a non-migratory PVC sheath; or
- (d) Separating cables from polystyrene insulation, as specified by the insulation manufacturer.

#### **C3.5**

*Contact between polystyrene insulation and PVC-coated cables can cause a chemical reaction, which can damage the insulation.*

## SECTION 4

# LIGHTING

- 4.1 General
- 4.2 Installing insulation near recessed luminaires
- 4.3 Installing insulation near surface-mounted luminaires
- 4.4 Installing insulation near independent controlgear in ceilings
- 4.5 Installing insulation near independent controlgear in subfloor spaces
- 4.6 Installing insulation near fan/heat/light units

Copyright Standards New Zealand

Copyright Standards New  
Zealand

## 4 LIGHTING

### 4.1 General

Luminaires and related independent controlgear emit heat while in use. Depending on the type of luminaire and how it is installed in proximity to nearby insulation, clearances between the insulation and the luminaire and related independent controlgear may be required to prevent overheating, which could result in fire or damage to the luminaire and building materials, or shorten their life. At the same time clearances in thermal insulation compromise insulation effectiveness.

This section provides information on installing insulation safely in the vicinity of luminaires and independent controlgear while maximising the insulation effectiveness. This information is limited to situations where the *luminaires and independent controlgear are already in place* before the insulation is installed.

#### **C4.1**

*Under the Electricity (Safety) Regulations, clause 17(4) 'A person commits an offence and is liable on conviction to a level 2 penalty if the person places thermal insulating material on or around fittings in an installation in such a way that the safety of the installation is compromised.'*

### 4.2 Installing insulation near recessed luminaires

#### 4.2.1 Safe and effective installation in ceilings and walls

The safe and effective installation of insulation around recessed luminaires in ceilings and walls is set out in 4.2.

#### **C4.2.1**

*Recessed luminaires (commonly known as downlights) are mainly installed in ceilings but may also be installed in walls or floors where they may be in close vicinity to insulation.*

*Some existing recessed luminaires require clearances to insulation. Where clearances are required they can cause a significant reduction in the insulation performance and can result in mould growth on the parts of the ceiling or wall surface that remain uninsulated. In addition, many older recessed luminaires allow for conditioned (heated or cooled) air to escape from the habitable area through the building envelope, or cold air to enter from the roof space.*

*Removing recessed luminaires that require clearances, or replacing them with recessed luminaires that can be insulated up to or over them, improves insulation effectiveness.*


**4.2.2 Installing insulation near recessed luminaires in ceilings**

The following steps shall be taken when installing insulation near recessed luminaires in ceilings.


Step	Action
1.	Identify recessed luminaires and any related independent controlgear in the area where insulation is being installed.  See 4.4 for information on installing ceiling insulation safely in the vicinity of independent controlgear.
2.	Follow the specified clearances of the recessed luminaire manufacturer where they are known. Ensure that the insulation product is compatible with the recessed luminaire. Refer to the insulation manufacturer's instructions or contact the insulation manufacturer.
3.	If the recessed luminaire manufacturer's specifications are not known: <ul style="list-style-type: none"> <li data-bbox="560 763 1437 907">(a) Look for a classification mark on the top of the recessed luminaire to identify the type of recessed luminaire. Repeat this for each recessed luminaire as there may be different types of recessed luminaires installed within the same building;</li> <li data-bbox="560 913 1437 952">(b) Follow Table 1 for the relevant type of recessed luminaire.</li> </ul> If the type of recessed luminaire cannot be clearly identified, for example where the classification mark is illegible, follow Table 1 for the type 'Other (not marked CA 80, CA 90, CA 135, IC, IC-F or IC-4)'.
4.	Ensure any required clearances are maintained for both the newly installed insulation and any existing insulation in the area where insulation is being installed.
5.	Where insulation is installed in an accessible roof space around recessed luminaires that require clearances between the insulation and the recessed luminaire, a warning sign should be installed in the roof space in accordance with Appendix C.

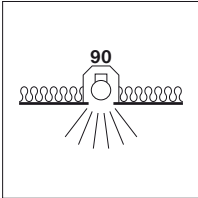


**Table 1 – Installing ceiling insulation where recessed luminaires are already in place and where the luminaire manufacturer’s instructions are not known**

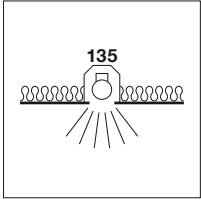
Type	Mark	Action
<p>CA 80 (as per AS/NZS 60598.2.2:2001, incorporating NZ-only Amendment A)</p>		<p><b>DO NOT COVER THE LUMINAIRE WITH INSULATION</b></p> <p>In the vicinity of the recessed luminaire, use an insulation product that:</p> <ul style="list-style-type: none"> <li>(a) Maintains its dimensions and structural integrity when exposed to a temperature of 90°C, and</li> <li>(b) Withstands a 30-second needle flame test carried out in accordance with AS/NZS 60695.11.5 with the flame applied to all surfaces of the sample.</li> </ul> <p>Refer to the insulation manufacturer’s instructions or contact the insulation manufacturer.</p> <p>Clear any existing loose-fill insulation at least 300 mm away from the luminaire.</p> <p>Abut the insulation to the sides of the luminaire. Ensure that the opening area of the hole in the insulation at the top of the insulation layer is at least the same as at the bottom of the insulation. The insulation shall not encroach into the space immediately above the recessed luminaire. Block off any gaps between the ceiling insulation and the ceiling lining around the luminaire (see 6.2.9).</p> <p>See Figures 2 and 3.</p> <p><b>Loose-fill insulation only:</b> If installing new loose-fill insulation, place a guard or recessed luminaire barrier around the luminaire to prevent loose-fill insulation contacting the luminaire. Fit the guard or recessed luminaire barrier so that it extends at least 75 mm above the installed insulation layer and make sure it is permanently fixed to prevent dislodgement when installing insulation. Insulate any horizontal gaps between the luminaire and the guard with an alternative insulation material that is suitable for abutting to CA 80 recessed luminaires. See Figure 4.</p>


**Table 1 – Installing ceiling insulation where recessed luminaires are already in place and where the luminaire manufacturer’s instructions are not known (continued)**

Type	Mark	Action
<p>CA 135 (as per AS/NZS 60598.2.2:2001, incorporating NZ-only Amendment A)</p>		<p><b>DO NOT COVER THE LUMINAIRE WITH INSULATION</b></p> <p>In the vicinity of the recessed luminaire, use an insulation product that:</p> <ul style="list-style-type: none"> <li>(a) Maintains its dimensions and structural integrity when exposed to a temperature of 150°C, and</li> <li>(b) Withstands a 30-second needle flame test carried out in accordance with AS/NZS 60695.11.5 with the flame applied to all surfaces of the sample.</li> </ul> <p>Refer to the insulation manufacturer’s instructions or contact the insulation manufacturer.</p> <p>Clear any existing loose-fill insulation at least 300 mm away from the luminaire.</p> <p>Abut the insulation to the sides of the luminaire. Ensure that the opening area of the hole in the insulation at the top of the insulation layer is at least the same as at the bottom of the insulation. The insulation shall not encroach into the space immediately above the recessed luminaire. Block off any gaps between the ceiling insulation and the ceiling lining around the luminaire (see 6.2.9).</p> <p>See Figures 2 and 3.</p> <p><b>Loose-fill insulation only:</b> If installing new loose-fill insulation, place a guard or recessed luminaire barrier around the luminaire to prevent loose-fill insulation contacting the luminaire. Fit the guard or recessed luminaire barrier so that it extends at least 75 mm above the installed insulation layer and make sure it is permanently fixed to prevent dislodgement when installing insulation. Insulate any horizontal gaps between the luminaire and the guard with an alternative insulation material that is suitable for abutting to CA 135 recessed luminaires. See Figure 4.</p>


Type	Mark	Action
<p>CA 90 (as per AS/NZS 60598.2.2:2016)</p>		<p><b>DO NOT COVER THE LUMINAIRE WITH INSULATION</b></p> <p>In the vicinity of the recessed luminaire, use an insulation product that:</p> <ul style="list-style-type: none"> <li>(a) Maintains its dimensions and structural integrity when exposed to a temperature of 90°C;</li> <li>(b) Withstands a 30-second needle flame test carried out in accordance with AS/NZS 60695.11.5 with the flame applied to all surfaces of the sample; and</li> <li>(c) Has an ignition temperature of at least 200°C (with the ignition temperature determined using a test period of 15 minutes).</li> </ul> <p>Refer to the insulation manufacturer's instructions or contact the insulation manufacturer.</p> <p>Clear any existing loose-fill insulation at least 300 mm away from the luminaire.</p> <p>Abut the insulation to the sides of the luminaire. Ensure that the opening area of the hole in the insulation at the top of the insulation layer is at least the same as at the bottom of the insulation. The insulation shall not encroach into the space immediately above the recessed luminaire. Block off any gaps between the ceiling insulation and the ceiling lining around the luminaire (see 6.2.9).</p> <p>See Figures 2 and 3.</p> <p><b>Loose-fill insulation only:</b> If installing new loose-fill insulation, place a guard or recessed luminaire barrier around the luminaire to prevent loose-fill insulation contacting the luminaire. Fit the guard or recessed luminaire barrier so that it extends at least 75 mm above the installed insulation layer and make sure it is permanently fixed to prevent dislodgement when installing insulation. Insulate any horizontal gaps between the luminaire and the guard with an alternative insulation material that is suitable for abutting to CA 90 recessed luminaires. See Figure 4.</p>

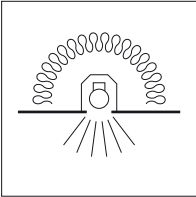
**Table 1 – Installing ceiling insulation where recessed luminaires are already in place and where the luminaire manufacturer’s instructions are not known (continued)**

Type	Mark	Action
<p>CA 135 (as per AS/NZS 60598.2.2:2016)</p>		<p><b>DO NOT COVER THE LUMINAIRE WITH INSULATION</b></p> <p>In the vicinity of the recessed luminaire, use an insulation product that:</p> <ul style="list-style-type: none"> <li>(a) Maintains its dimensions and structural integrity when exposed to a temperature of 135°C;</li> <li>(b) Withstands a 30-second needle flame test carried out in accordance with AS/NZS 60695.11.5 with the flame applied to all surfaces of the sample; and</li> <li>(c) Has an ignition temperature of at least 200°C (with the ignition temperature determined using a test period of 15 minutes).</li> </ul> <p>Refer to the insulation manufacturer’s instructions or contact the insulation manufacturer.</p> <p>Clear any existing loose-fill insulation at least 300 mm away from the luminaire.</p> <p>Abut the insulation to the sides of the luminaire. Ensure that the opening area of the hole in the insulation at the top of the insulation layer is at least the same as at the bottom of the insulation. The insulation shall not encroach into the space immediately above the recessed luminaire. Block off any gaps between the ceiling insulation and the ceiling lining around the luminaire (see 6.2.9).</p> <p>See Figures 2 and 3.</p> <p><b>Loose-fill insulation only:</b> If installing new loose-fill insulation, place a guard or recessed luminaire barrier around the luminaire to prevent loose-fill insulation contacting the luminaire. Fit the guard or recessed luminaire barrier so that it extends at least 75 mm above the installed insulation layer and make sure it is permanently fixed to prevent dislodgement when installing insulation. Insulate any horizontal gaps between the luminaire and the guard with an alternative insulation material that is suitable for abutting to CA 135 recessed luminaires. See Figure 4.</p>

Type	Mark	Action
<p>IC (as per AS/NZS 60598.2.2:2001, incorporating NZ-only Amendment A)</p>		<p>In the vicinity of the recessed luminaire, use an insulation product that:</p> <ul style="list-style-type: none"> <li>(a) Maintains its dimensions and structural integrity when exposed to a temperature of 90°C; and</li> <li>(b) Withstands a 30-second needle flame test carried out in accordance with AS/NZS 60695.11.5 with the flame applied to all surfaces of the sample.</li> </ul> <p>Refer to the insulation manufacturer's instructions or contact the insulation manufacturer.</p> <p>Clear any existing loose-fill insulation at least 300 mm away from the luminaire.</p> <p>Abut the insulation to the sides of the luminaire. Place an additional piece of insulation no smaller than 300 mm × 300 mm over the top of the luminaire.</p> <p>See Figures 5 and 6.</p> <p><b>Loose-fill insulation only:</b> If installing new loose-fill insulation, place a guard or recessed luminaire barrier around the luminaire to prevent loose-fill insulation contacting the luminaire. Fit the guard or recessed luminaire barrier so that it extends at least 75 mm above the installed insulation layer and make sure it is permanently fixed to prevent dislodgement when installing insulation. Insulate any horizontal gaps between the luminaire and the guard with an alternative insulation material that is suitable for abutting to and covering IC recessed luminaires. Place an additional piece of alternative insulation material over the top of the luminaire.</p> <p>See Figure 7.</p>

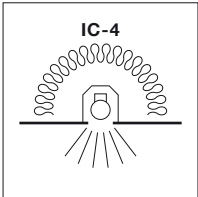
**Table 1 – Installing ceiling insulation where recessed luminaires are already in place and where the luminaire manufacturer’s instructions are not known (continued)**

Type	Mark	Action
IC-F (as per AS/NZS 60598.2.2:2001, incorporating NZ-only Amendment A)		<p>In the vicinity of the recessed luminaire, use an insulation product that:</p> <ul style="list-style-type: none"> <li>(a) Maintains its dimensions and structural integrity when exposed to a temperature of 90°C; and</li> <li>(b) Withstands a 30-second needle flame test carried out in accordance with AS/NZS 60695.11.5 with the flame applied to all surfaces of the sample.</li> </ul> <p>Refer to the insulation manufacturer’s instructions or contact the insulation manufacturer.</p> <p>Clear any existing loose-fill insulation at least 300 mm away from the luminaire.</p> <p>Abut the insulation to the sides of the luminaire. Place an additional piece of insulation no smaller than 300 mm × 300 mm over the top of the luminaire.</p> <p>See Figures 5 and 6.</p> <p><b>Loose-fill insulation only:</b> If installing new loose-fill insulation, place a guard or recessed luminaire barrier around the luminaire to prevent loose-fill insulation contacting the luminaire. Fit the guard or recessed luminaire barrier so that it extends at least 75 mm above the installed insulation layer and make sure it is permanently fixed to prevent dislodgement when installing insulation. Insulate any horizontal gaps between the luminaire and the guard with an alternative insulation material that is suitable for abutting to and covering IC-F recessed luminaires. Place an additional piece of alternative insulation material over the top of the luminaire.</p> <p>See Figure 7.</p>

Type	Mark	Action
<p>IC (as per AS/NZS 60598.2.2:2016)</p>		<p>In the vicinity of the recessed luminaire, use an insulation product that:</p> <ul style="list-style-type: none"> <li>(a) Maintains its dimensions and structural integrity when exposed to a temperature of 90°C;</li> <li>(b) Withstands a 30-second needle flame test carried out in accordance with AS/NZS 60695.11.5 with the flame applied to all surfaces of the sample; and</li> <li>(c) Has an ignition temperature of at least 200°C (with the ignition temperature determined using a test period of 15 minutes).</li> </ul> <p>Refer to the insulation manufacturer's instructions or contact the insulation manufacturer.</p> <p>Clear any existing loose-fill insulation at least 300 mm away from the luminaire.</p> <p>Abut the insulation to the sides of the luminaire. Place an additional piece of insulation no smaller than 300 mm × 300 mm over the top of the luminaire.</p> <p>See Figures 5 and 6.</p> <p><b>Loose-fill insulation only:</b> If installing new loose-fill insulation, place a guard or recessed luminaire barrier around the luminaire to prevent loose-fill insulation contacting the luminaire. Fit the guard or recessed luminaire barrier so that it extends at least 75 mm above the installed insulation layer and make sure it is permanently fixed to prevent dislodgement when installing insulation. Insulate any horizontal gaps between the luminaire and the guard with an alternative insulation material that is suitable for abutting to and covering IC recessed luminaires. Place an additional piece of alternative insulation material over the top of the luminaire.</p> <p>See Figure 7.</p>



**Table 1 – Installing ceiling insulation where recessed luminaires are already in place and where the luminaire manufacturer’s instructions are not known (continued)**

Type	Mark	Action
<p>IC-4 (as per AS/NZS 60598.2.2:2016)</p>		<p>In the vicinity of the recessed luminaire, use an insulation product that:</p> <ul style="list-style-type: none"> <li>(a) Maintains its dimensions and structural integrity when exposed to a temperature of 90°C;</li> <li>(b) Withstands a 30-second needle flame test carried out in accordance with AS/NZS 60695.11.5 with the flame applied to all surfaces of the sample; and</li> <li>(c) Has an ignition temperature of at least 200°C (with the ignition temperature determined using a test period of 15 minutes).</li> </ul> <p>Refer to the insulation manufacturer’s instructions or contact the insulation manufacturer.</p> <p>Clear any existing loose-fill insulation at least 300 mm away from the luminaire.</p> <p>Abut the insulation to the sides of the luminaire. Place an additional piece of insulation no smaller than 300 mm × 300 mm over the top of the luminaire.</p> <p>See Figures 5 and 6.</p> <p><b>Loose-fill insulation only:</b> If installing new loose-fill insulation, place a guard or recessed luminaire barrier around the luminaire to prevent loose-fill insulation contacting the luminaire. Fit the guard or recessed luminaire barrier so that it extends at least 75 mm above the installed insulation layer and make sure it is permanently fixed to prevent dislodgement when installing insulation. Insulate any horizontal gaps between the luminaire and the guard with an alternative insulation material that is suitable for abutting to and covering IC-4 recessed luminaires. Place an additional piece of alternative insulation material over the top of the luminaire.</p> <p>See Figure 7.</p>



Type	Mark	Action
Other (not marked CA 80, CA 90, CA 135, IC, IC-F or IC-4)	No mark or any other mark (including Non-IC)	<p><b>DO NOT COVER THE LUMINAIRE WITH INSULATION</b></p> <p>Recommend to the building owner that the existing luminaire be replaced with a new recessed luminaire of a type that can be safely covered with insulation.</p> <p>If the building owner chooses to replace existing recessed luminaires then this should be done before the installation of insulation commences. If the recessed luminaire is replaced, follow the luminaire manufacturer's instructions when installing the insulation.</p> <p>If the recessed luminaire is not replaced, maintain a minimum clearance of 100 mm to the luminaire (including the lamp). Any existing insulation shall be cleared away from the luminaire to maintain the required clearance.</p> <p>Clearances for new loose-fill insulation shall be set by placing a guard or recessed luminaire barrier around the luminaire. Fit the guard or recessed luminaire barrier so that it extends at least 75 mm above the installed insulation layer and make sure it is permanently fixed to prevent dislodgement when installing insulation. See Figure 8.</p> <p>For all other insulation materials clearances shall be set by either:</p> <ul style="list-style-type: none"> <li>(a) Placing a permanently fixed guard or recessed luminaire barrier around the luminaire (see Figure 8); or</li> <li>(b) Permanently securing all insulation near the recessed luminaire in position. Acceptable means of permanently securing insulation in position include mechanically fixing or gluing insulation to the ceiling framing or lining, or, for semi-rigid or rigid sheet insulation, firm friction-fitting of all insulation pieces between framing. Clear any existing loose-fill insulation at least 300 mm away from the luminaire and block off with the new, permanently fixed insulation in a way that prevents loose-fill insulation contacting the luminaire. See Figure 9.</li> </ul> <p>Block off any gaps between the ceiling insulation and the ceiling lining around the luminaire (see 6.2.9).</p>

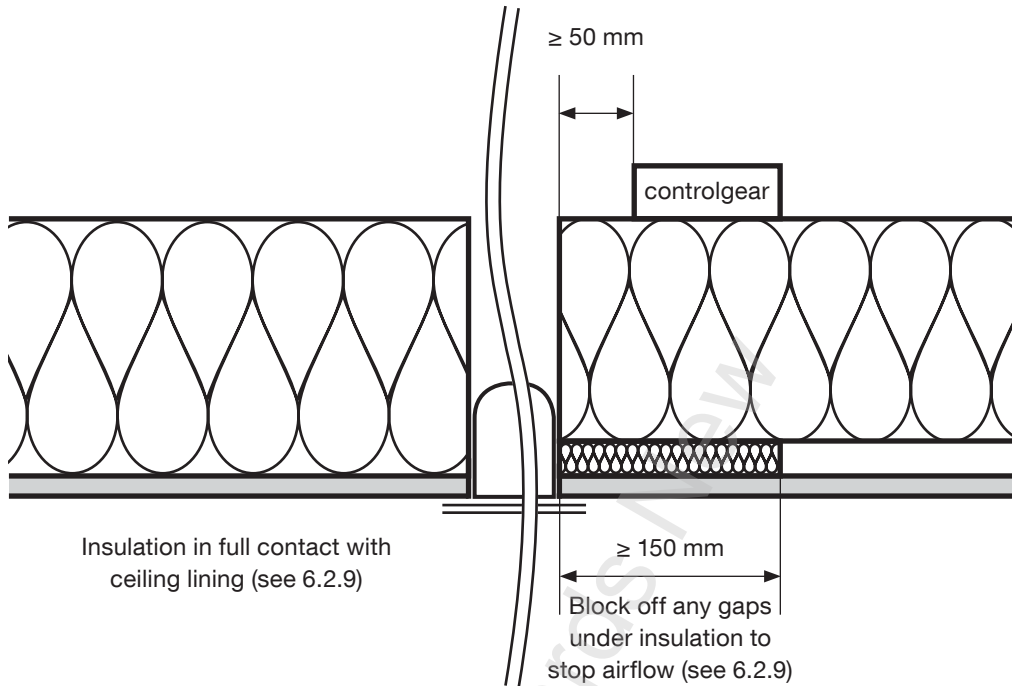


Figure 2 – Installing ceiling insulation around recessed luminaires of the type CA 80, CA 90, and CA 135 where the luminaire manufacturer’s instructions are not known

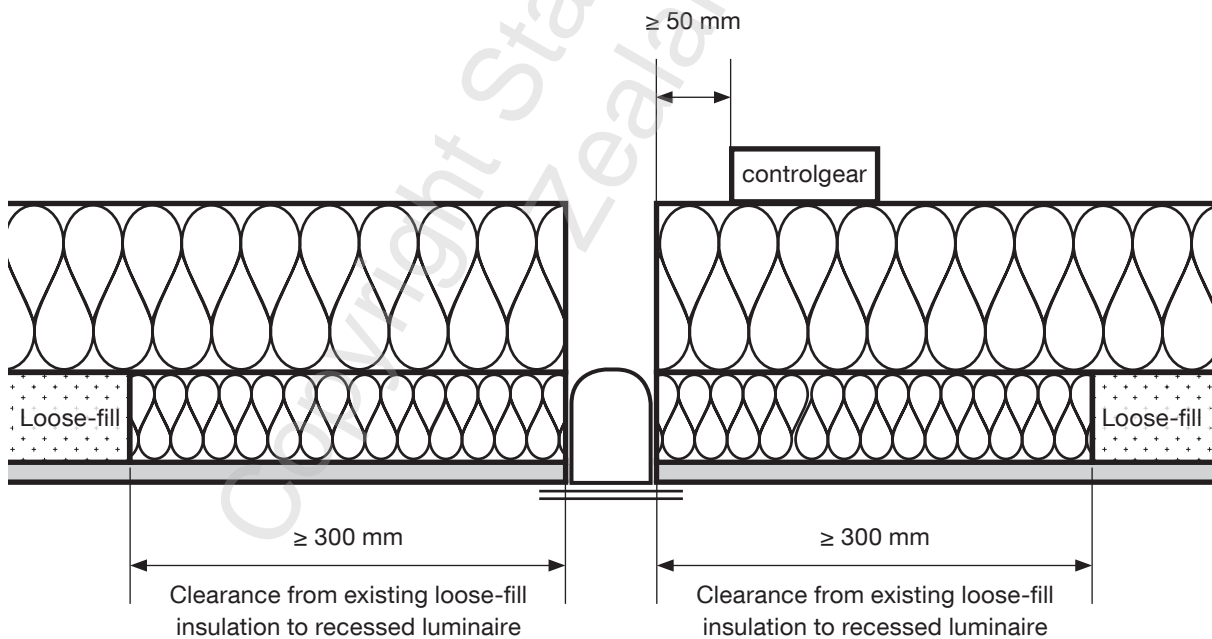
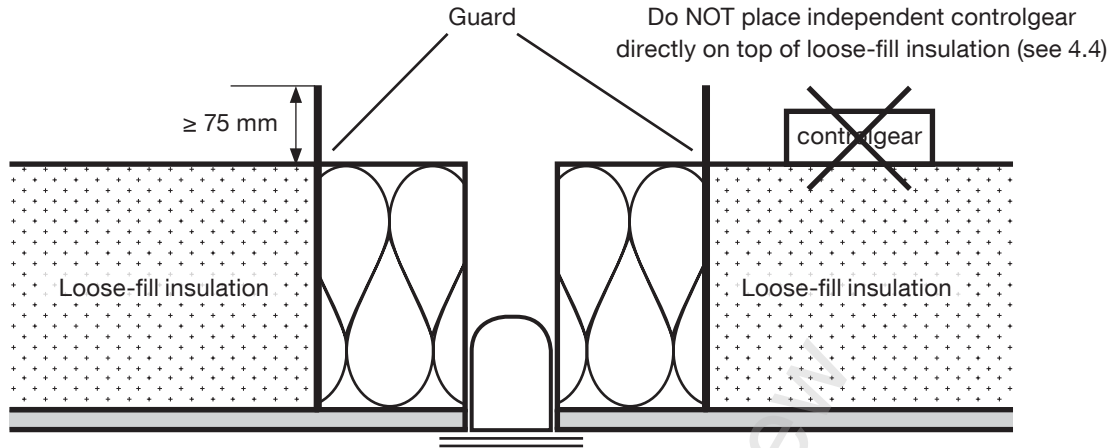
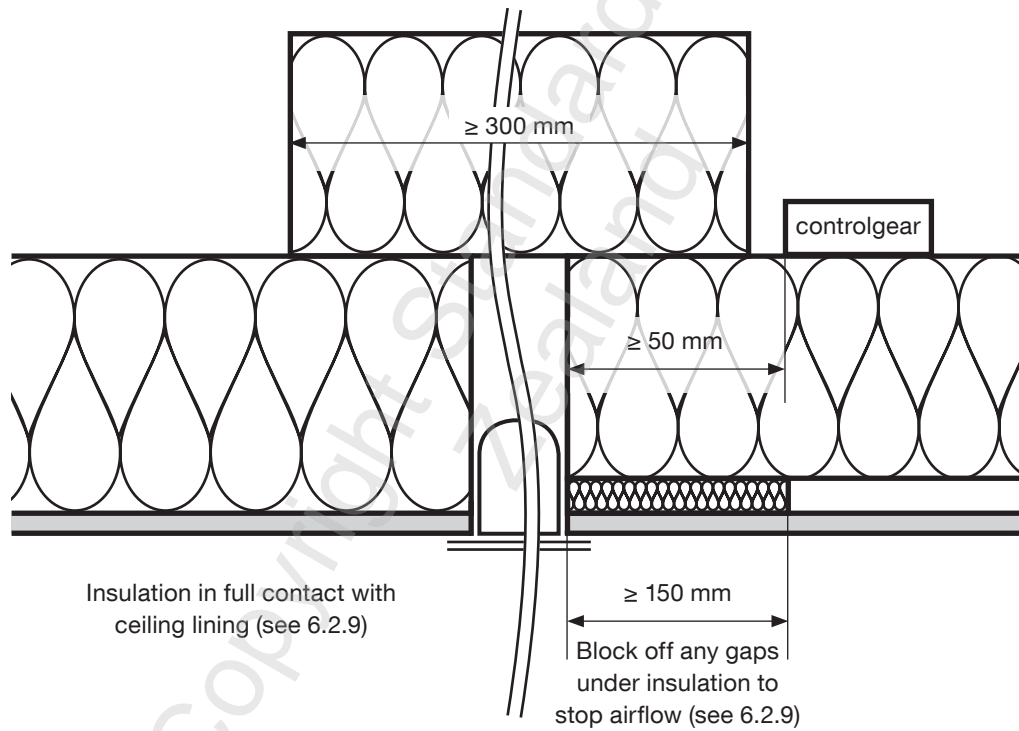


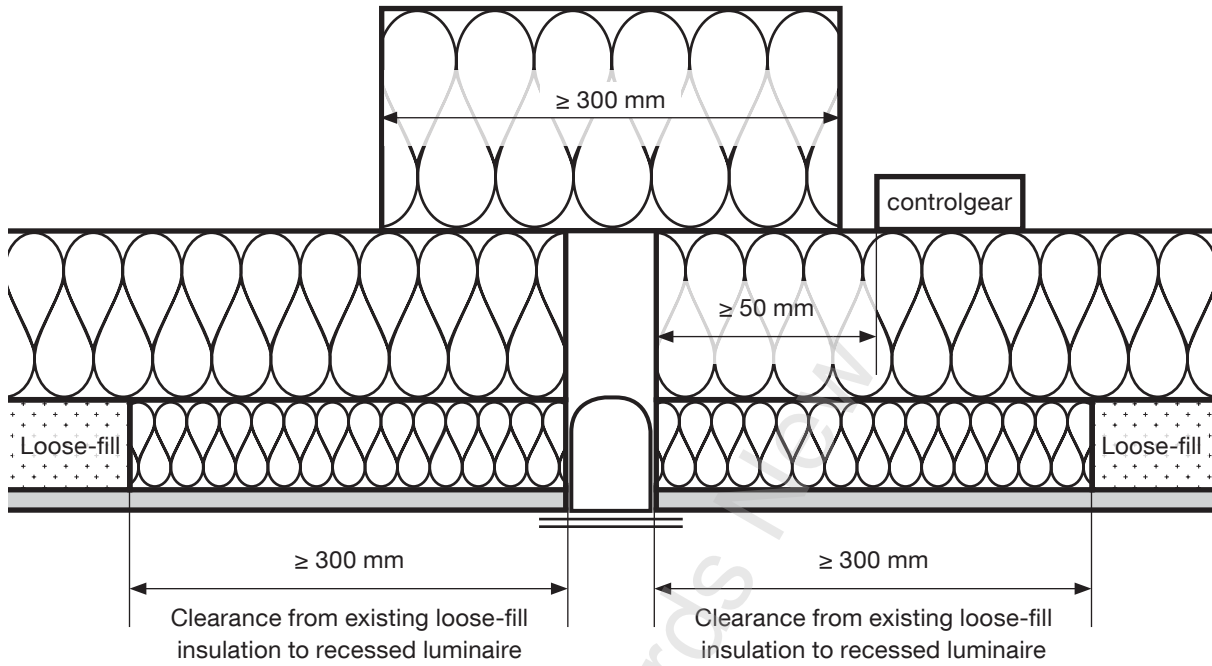
Figure 3 – Installing ceiling insulation around recessed luminaires of the type CA 80, CA 90, and CA 135 where the luminaire manufacturer’s instructions are not known (ceilings with existing loose-fill insulation)



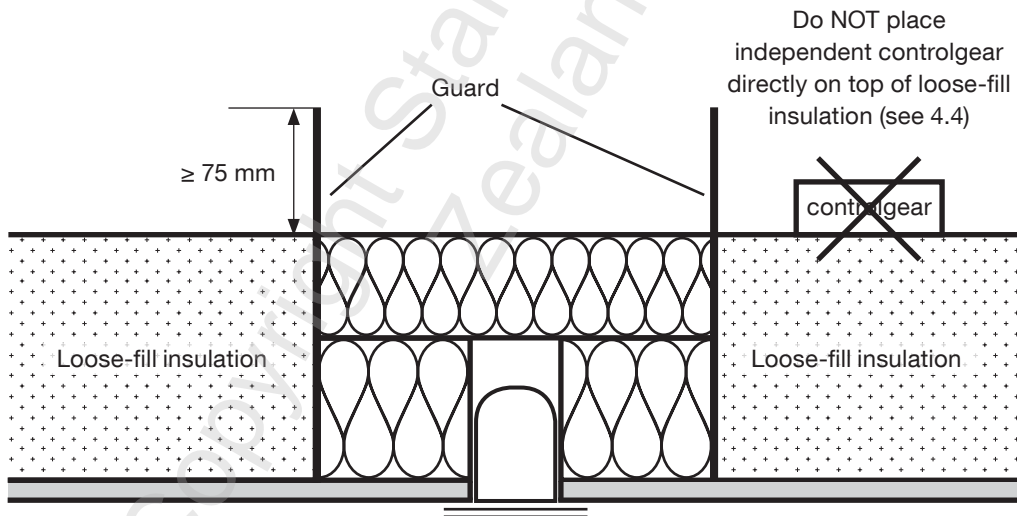
**Figure 4 – Installing new loose-fill ceiling insulation around recessed luminaires of the type CA 80, CA 90, and CA 135 where the luminaire manufacturer’s instructions are not known**



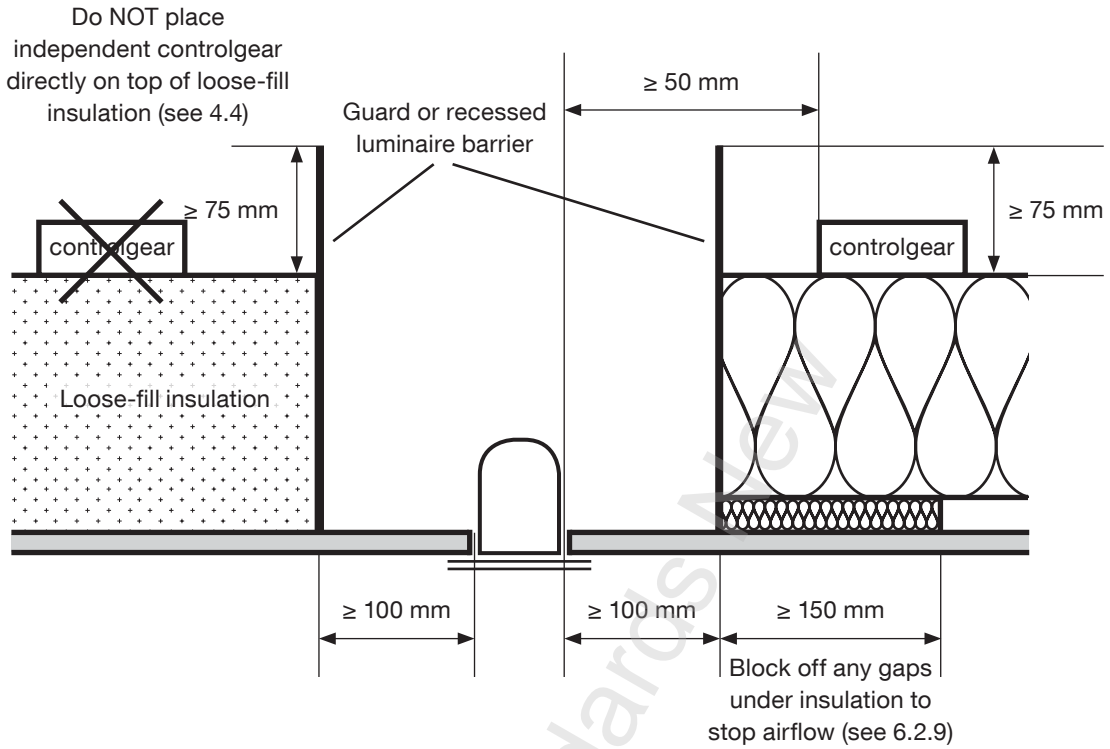
**Figure 5 – Installing ceiling insulation around recessed luminaires of the type IC, IC-F, and IC-4 where the luminaire manufacturer’s instructions are not known**



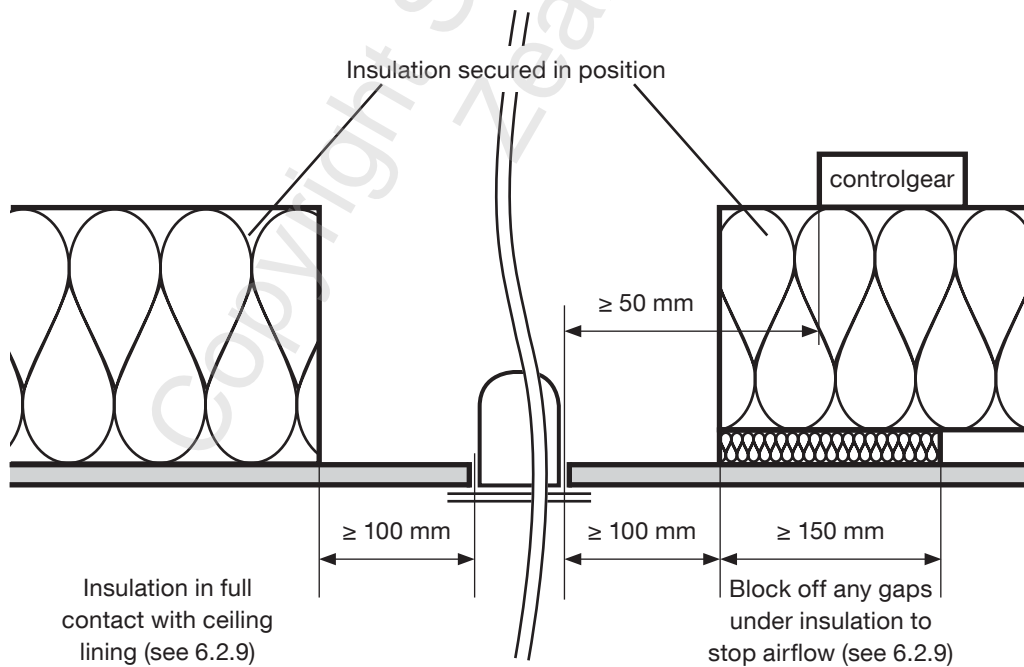
**Figure 6 – Installing ceiling insulation around recessed luminaires of the type IC, IC-F, and IC-4 where the luminaire manufacturer’s instructions are not known (ceilings with existing loose-fill insulation)**



**Figure 7 – Installing new loose-fill ceiling insulation around recessed luminaires of the type IC, IC-F, and IC-4 where the luminaire manufacturer’s instructions are not known**



**Figure 8 – Installing ceiling insulation around recessed luminaires that are NOT of the type CA 80, CA 90, CA 135, IC, IC-F, or IC-4 where insulation is NOT secured in position or where insulation is loose-fill and where the luminaire manufacturer’s instructions are not known**



**Figure 9 – Installing ceiling insulation around recessed luminaires that are NOT of the type CA 80, CA 90, CA 135, IC, IC-F, or IC-4 where insulation is secured in position and where the luminaire manufacturer’s instructions are not known**

**4.2.3 Installing insulation near recessed luminaires in walls**

The following steps shall be taken when installing insulation near recessed luminaires in walls.

Step	Action
1.	Identify recessed luminaires and any related independent controlgear in the area where insulation is being installed.
2.	Follow the specified clearances of the recessed luminaire and independent controlgear manufacturers where they are known (make sure these apply to installations in walls).
3.	If the manufacturer's specified clearances are not known recommend to the building owner that the existing luminaire be replaced with a new recessed luminaire of a type that can be safely covered and surrounded with insulation. Where the recessed luminaire is replaced, follow the manufacturer's instructions (make sure these apply to installations in walls). Otherwise consult a registered electrician for guidance on clearances required between the insulation and the luminaire, and any independent controlgear.
4.	Ensure any required clearances are maintained for both the newly installed insulation and any existing insulation in the area where insulation is being installed.

**4.3 Installing insulation near surface-mounted luminaires**

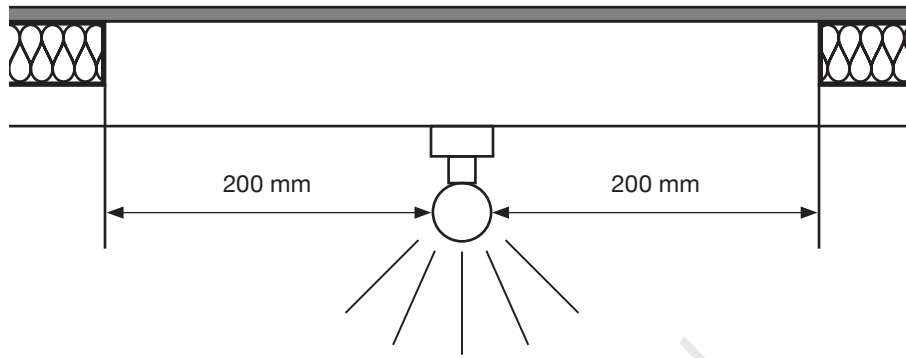
Surface-mounted luminaires do not protrude through any part of the ceiling or wall lining and are mainly installed under ceilings and on walls, but may also be installed in other locations such as inside roof cavities or in subfloor spaces where they can be in close vicinity to where insulation is being installed.

Some surface-mounted luminaires may include independent controlgear (such as transformers, ballasts, and drivers).

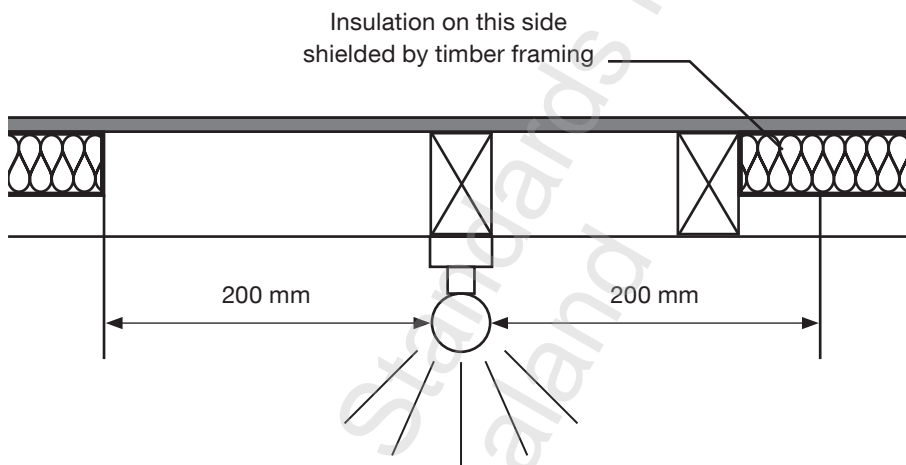
Where it is possible, surface-mounted luminaires and any related independent controlgear should be relocated by a registered electrician before insulation installation, to avoid gaps in the insulation layer.

Otherwise insulation shall be kept clear of surface-mounted luminaires and their independent controlgear as follows.

Step	Action
1.	<p>Identify surface-mounted luminaires in the area where insulation is being installed. This includes surface mounted luminaires in roof and subfloor spaces.</p> <p>See 4.4 and 4.5 for information on installing insulation safely in the vicinity of independent controlgear.</p>
2.	<p>Follow the specified clearances of the surface-mounted luminaire manufacturer where they are known.</p>
3.	<p>If the manufacturer's specified clearances are not known, maintain a minimum clearance of 200 mm to the surface-mounted luminaire or lamp. This clearance applies in all directions regardless of the type, location and orientation of the surface-mounted luminaire (see Figures 10 – 13).</p> <p>The clearance does not need to extend to areas where insulation is fully and permanently shielded from the luminaire and lamp by framing, plasterboard, or similar shielding material. Where there is potential for insulation to loft over time, ensure the insulation remains shielded after lofting; otherwise maintain a minimum clearance of 200 mm to the luminaire. Check the nominal insulation thickness on the product label.</p>
4.	<p>Clearances for new loose-fill insulation shall be set by placing a guard around the luminaire. Fit the guard so that it extends at least 75 mm above the installed insulation layer and make sure it is permanently fixed to prevent dislodgement when installing insulation.</p> <p>For all other insulation materials clearances shall be set by either:</p> <ol style="list-style-type: none"> <li>Placing a permanently fixed guard around the luminaire; or</li> <li>Permanently securing all insulation near the luminaire in position. Acceptable means of permanently securing insulation in position include mechanically fixing or gluing insulation to the building element or, for semi-rigid or rigid sheet insulation, firm friction-fitting of all insulation pieces between framing. Clear any existing loose-fill insulation at least 300 mm away from the luminaire and block off with the new, permanently fixed insulation in a way that prevents loose-fill insulation contacting the luminaire.</li> </ol> <p>Ensure these clearances are maintained for both the newly installed insulation and any existing insulation in the area where insulation is being installed.</p>

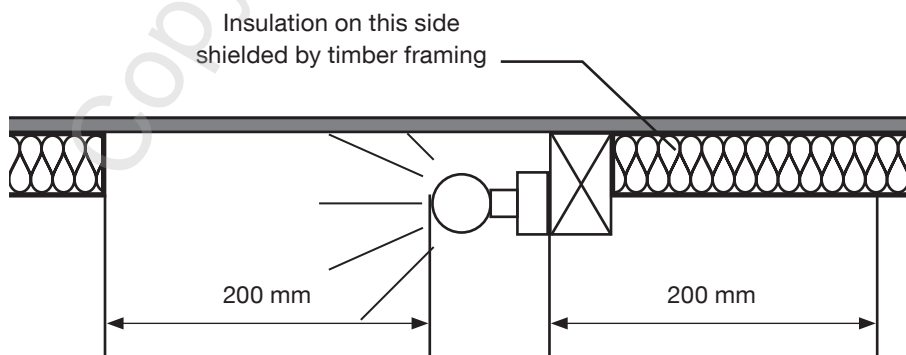


**Figure 10 – Example of underfloor insulation installed with clearance around a light fitting mounted to the bottom of a floor joist**



On the right hand side a smaller clearance is acceptable as the insulation is fully and permanently shielded by timber framing.

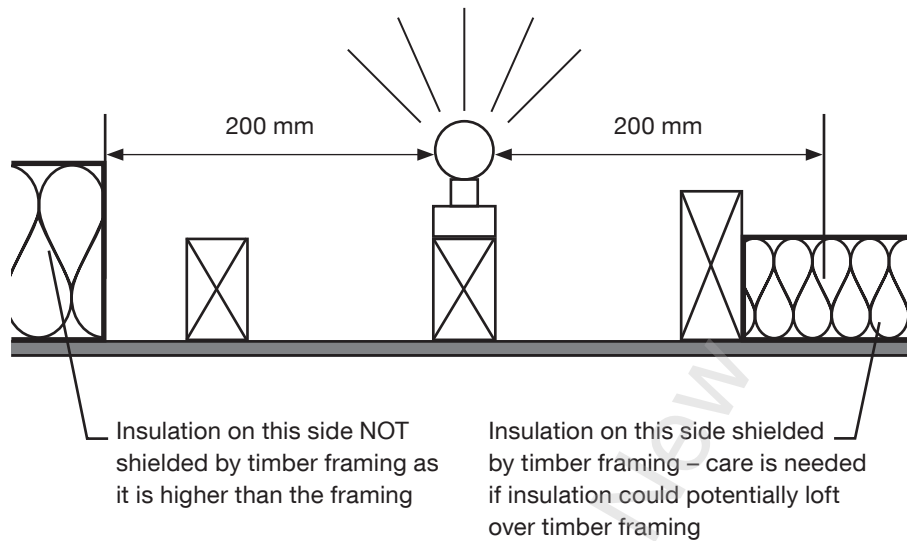
**Figure 11 – Example of underfloor insulation installed with clearance around a light fitting mounted to the bottom of a floor joist**



On the right hand side no clearance is required as the insulation is fully and permanently shielded by timber framing.

**Figure 12 – Example of underfloor insulation installed with clearance around a light fitting mounted to the side of a floor joist**





On the left hand side the top of the ceiling joist is lower than the top of the insulation and does not fully shield the insulation. The full clearance needs to be maintained. On the right hand side a smaller clearance is acceptable as the insulation is fully and permanently shielded by timber framing (provided the insulation material cannot potentially loft over the top of the ceiling joist – where this is not guaranteed the full 200 mm clearance shall be maintained).

**Figure 13 – Example of ceiling insulation installed with clearance around a light fitting mounted to the top of a ceiling joist**

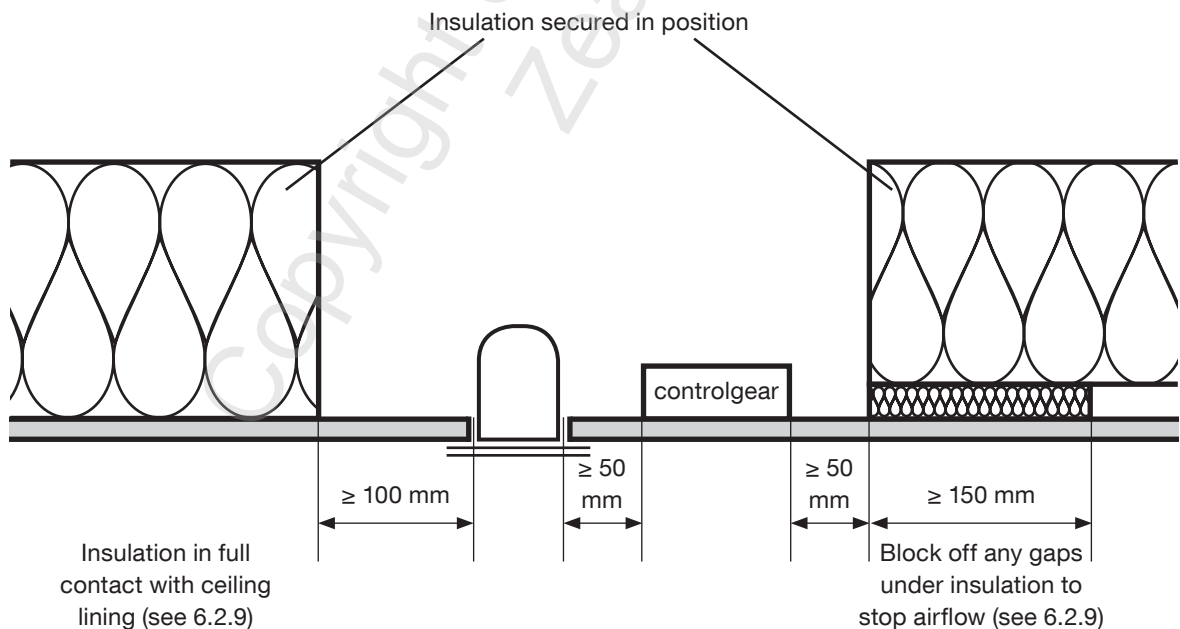
#### 4.4 Installing insulation near independent controlgear in ceilings

The following steps shall be taken when installing insulation near independent controlgear in ceilings.

Step	Action
1.	Identify independent controlgear (such as transformers, ballasts, and drivers) in the ceiling cavity in the area where insulation is being installed.
2.	Follow the specified clearances of the independent controlgear manufacturer where they are known.
3.	If the independent controlgear manufacturer’s specifications are not known: <ul style="list-style-type: none"> <li>(a) Lift any independent controlgear and place it on top of the insulation, provided it is safe and practicable to do so. Ensure the independent controlgear does not sink into the insulation to an extent that the insulation abuts to the sides of the independent controlgear. Do not place independent controlgear directly on top of loose-fill insulation. Ensure a minimum horizontal clearance of 50 mm is maintained between the independent controlgear and any luminaire. Take care to avoid damaging the electrical cables and equipment. In case of any damaged electrical cables or equipment these are to be repaired or replaced by a registered electrician before insulation installation proceeds. See Figures 2 – 9.</li> </ul>



Step	Action
	(b) Where it is not safe or practicable to reposition any independent controlgear, or where independent controlgear, when placed on top of the insulation, would sink into the insulation to an extent that the insulation abuts to its sides, maintain a minimum clearance of 50 mm from the insulation to the independent controlgear. Do not cover the independent controlgear. See Figures 14 and 15.
4.	<p>Set clearances for new loose-fill insulation by placing a guard around the independent controlgear. Fit the guard so that it extends at least 75 mm above the installed insulation layer and make sure it is permanently fixed to prevent dislodgement when installing insulation.</p> <p>For all other insulation materials clearances shall be set by either:</p> <ul style="list-style-type: none"> <li>(a) Placing a permanently fixed guard around the independent controlgear; or</li> <li>(b) Permanently securing all insulation near the independent controlgear in position. Acceptable means of permanently securing insulation in position include mechanically fixing or gluing insulation to the building element or, for semi-rigid or rigid sheet insulation, firm friction-fitting of all insulation pieces between framing. Clear any existing loose-fill insulation at least 300 mm away from the independent controlgear and block off with the new, permanently fixed insulation in a way that prevents loose-fill insulation contacting the independent controlgear.</li> </ul> <p>Ensure these clearances are maintained for both the newly installed insulation and any existing insulation in the area where insulation is being installed.</p>



Example shows a recessed luminaire that is NOT of the type CA 80, CA 90, CA 135, IC, IC-F, or IC-4 and where insulation is secured in position

**Figure 14 – Example of ceiling insulation clearance around a recessed luminaire and independent controlgear not placed on top of insulation**

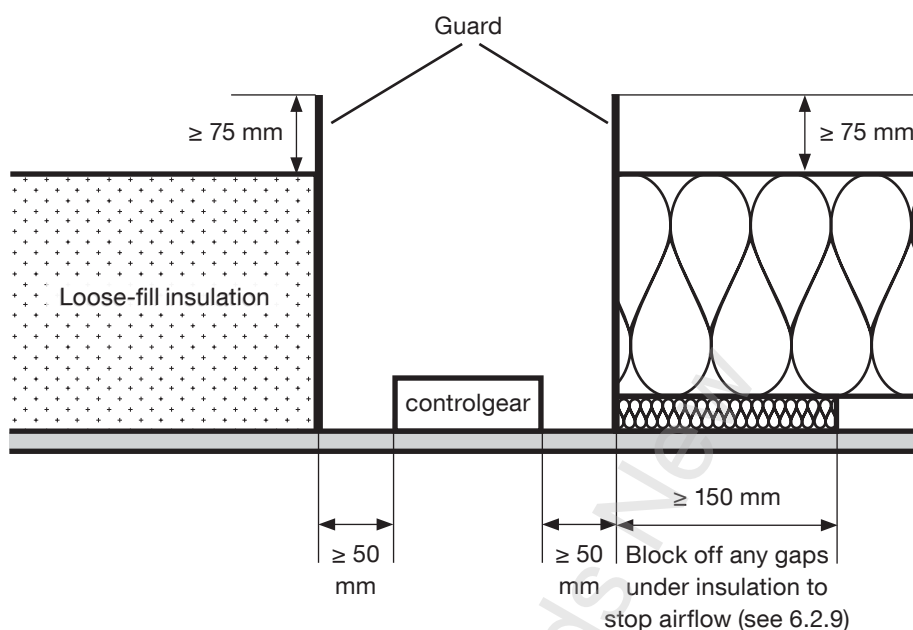


Figure 15 – Example of ceiling insulation clearance around independent controlgear not placed on top of insulation, where the manufacturer’s instructions are not known

#### 4.5 Installing insulation near independent controlgear in subfloor spaces

The following steps shall be taken when installing insulation near independent controlgear in subfloor spaces.

Step	Action
1.	Identify independent controlgear (such as transformers, ballasts, and drivers) in the subfloor space in the area where insulation is being installed.
2.	Follow the specified clearances of the independent controlgear manufacturer where they are known.
3.	If the independent controlgear manufacturer’s specifications are not known, maintain a minimum clearance of 50 mm from the insulation to the independent controlgear. Do not reposition and do not cover the independent controlgear.

## 4.6 Installing insulation near fan/heat/light units

The following steps shall be taken when installing insulation near fan/heat/light units.

Step	Action
1.	Follow the specified clearances of the fan/heat/light unit manufacturer where they are known.
2.	If the manufacturer's specified clearances are not known, maintain a minimum clearance of 100 mm to the fan/heat/light unit.
3.	<p>Clear any existing insulation away from the fan/heat/light unit to maintain the required clearance.</p> <p>Set clearances for new loose-fill insulation by placing a guard around the fan/heat/light unit. Fit the guard so that it extends at least 75 mm above the installed insulation layer and make sure it is permanently fixed to prevent dislodgement when installing insulation.</p> <p>For all other insulation materials clearances shall be set by either:</p> <ul style="list-style-type: none"> <li>(a) Placing a permanently fixed guard around the fan/heat/light unit; or</li> <li>(b) Permanently securing all insulation near the fan/heat/light unit in position. Acceptable means of permanently securing insulation in position include mechanically fixing or gluing insulation to the ceiling or, for semi-rigid or rigid sheet insulation, firm friction-fitting of all insulation pieces between timber framing. Clear any existing loose-fill insulation at least 300 mm away from the luminaire and block off with the new, permanently fixed insulation in a way that prevents loose-fill insulation contacting the luminaire.</li> </ul> <p>Block off any gaps between the ceiling insulation and the ceiling lining around the fan/heat/light unit (see 6.2.8).</p>

## SECTION 5

# WALLS

- 5.1 **General**
- 5.2 **Special considerations**
- 5.3 **Timber/steel-framed walls with wall underlay**
- 5.4 **Timber/steel-framed walls without wall underlay**
- 5.5 **Loose-fill wall insulation**
- 5.6 **Masonry walls**

Copyright Standards New Zealand

Copyright Standards New  
Zealand

## 5 WALLS

### 5.1 General

This section provides guidance for installing insulation in walls and shall be read in conjunction with sections 1 to 4.

### 5.2 Special considerations

#### 5.2.1 Building consent

For existing walls a building consent is required to retrofit insulation. See 2.3 for further information on when a building consent is required when installing insulation.

#### 5.2.2 Inspections before installing insulation in existing walls

Before installing insulation, the following checks shall be made by the insulation installer or alternatively the insulation installer shall confirm that these checks have been made.

Step	Action
1.	Check for health and safety hazards on site. Appendix B contains health and safety information.
2.	Make sure all cavities and materials are dry and cleaned of any waste or contaminants.
3.	Check the entire wall area and cavity for signs of moisture (for example, through leaking pipes or window flashings), moisture damage (for example, rot or mould), or borer. Check the bottom plate in particular. If in doubt, consult a suitably qualified building surveyor before the insulation is installed. If cladding is replaced with different material then a building consent is required.
4.	Where cladding is not being replaced, look for potential leakage areas such as cracks and gaps in the cladding, split, or rotten weatherboards, and missing, corroded, or ill-fitting flashings. Make sure any such deficiencies are remedied before installing wall insulation.
5.	If a green/black-coloured mould is found when opening the wall cavity, stop work immediately. Notify the building owner or other authorised person that a testing lab will need to identify if the mould is a toxic variety (stachybotrys).
6.	Remove non-toxic mould by thoroughly cleaning the surfaces with either a proprietary mould remover or a household bleach solution (100 ml of bleach per 1 litre of water). Allow surfaces to dry thoroughly.  The building owner will need to have a specialist contractor remove toxic mould (stachybotrys) before insulation installation continues.
7.	Refer all incidences of rot or borer to the building owner for appropriate remediation before installing insulation.
8.	Where cladding is not being replaced, check for the presence and condition of wall underlay behind the cladding.

Step	Action
9.	Confirm that a registered electrician has inspected all wiring inside the wall cavities and has confirmed that the wiring is in good condition and suitable for being surrounded by thermal insulation. Rewiring or installation of circuit breakers may be necessary where wiring is inadequately rated or in a poor condition.
10.	Identify areas where insulation clearances from flues, ovens, space heating, and other in-built or free-standing appliances will be necessary. See 5.2.5 for detailed clearance information.
11.	<p>If an insulation product has already been selected, check that the product has the correct nominal thickness and width so the insulation can be installed into the wall cavity without tucks, compression, sagging, or gaps with minimum cutting required.</p> <p>The thickness and width are specified on the pack label of the insulation product. Some insulation products can take time to reach full loft (size).</p> <p>In framed walls without wall underlay or where the existing wall underlay is in poor condition, check the insulation product requirements specific to the existing wall construction, chosen insulation product type, and retrofit method:</p> <ul style="list-style-type: none"> <li>(a) When retrofitting insulation in exterior walls without wall underlay with direct-fixed claddings (see 5.4.2);</li> <li>(b) When retrofitting insulation in exterior walls without wall underlay with drained/veneer cavities (see 5.4.3).</li> </ul> <p>For masonry walls, only install insulation products intended for use over masonry walls.</p>

**5.2.3 Inspections before installing insulation in new walls**

Before installing insulation, the following checks shall be made by the insulation installer or alternatively the insulation installer shall confirm that these checks have been made.

Step	Action
1.	Check for health and safety hazards on site. Appendix B contains health and safety information.
2.	Make sure all cavities and materials are dry and cleaned of any waste or contaminants.
3.	<p>Do not start installing insulation until the cladding system is completely installed or the building is weathertight, except for cavities that can only be accessed from the outside.</p> <p>Insulate cavities that are only accessible from the outside before the wall underlay is installed, either using insulation products that can withstand exposure to weather until the cladding is installed, or by immediately protecting the insulation.</p> <p>NOTE – In new constructions some cavities between framing members can only be accessed from the outside and become inaccessible once the wall underlay is installed. Examples are external wall corners and internal to external wall connections.</p>



Step	Action
4.	Identify areas where insulation clearances from hot surfaces such as flues and behind ovens and space heating appliances will be necessary (detailed clearance requirements are provided in 5.2.5).
5.	<p>If an insulation product has already been selected, check that the product has the correct nominal thickness and width so the insulation can fill the wall cavity without tucks, compression, sagging, or gaps.</p> <p>The nominal thickness and width are specified on the pack label of the insulation product. Some insulation products can take time to reach full loft (size).</p> <p>Make sure the insulation can be installed so it touches the framing, interior lining, and wall underlay on all six faces, without causing the wall underlay to bulge into any drained or veneer cavity.</p> <p>For masonry walls, only install insulation products intended for use over masonry walls.</p>

#### 5.2.4 Choosing a wall insulation product

The following steps shall be taken when choosing a wall insulation product.

Step	Action
1.	Make sure the insulation product complies with AS/NZS 4859.1. Refer to the product label of the insulation product for a compliance statement.
2.	Make sure the product is fit for purpose and designed for insulating walls. Refer to the manufacturer’s instructions and ensure the product complies with any building consent documents.
3.	<p>Check the insulation product has the correct nominal thickness and width so the insulation can be installed into the wall cavity without tucks, compression, sagging, or gaps.</p> <p>The nominal thickness and width are specified on the pack label of the insulation product.</p> <p>For all exterior walls, self-supporting insulation is recommended to minimise the risk of contact between the insulation/wall underlay and cladding.</p> <p>In exterior walls with wall underlay and in all interior walls, size the insulation to fill the entire framed cavity space, without undue compression of the product. Make sure the insulation is not thicker than the depth of the framing to prevent it from causing the wall underlay to bulge against the cladding.</p> <p>In timber-framed exterior walls without wall underlay or where the existing wall underlay is in poor condition, check the manufacturer’s installation guidelines for further insulation product requirements specific to the existing wall construction, chosen insulation product type, and retrofit method:</p> <ul style="list-style-type: none"> <li>(a) When retrofitting insulation in exterior walls without wall underlay with direct-fixed claddings (see 5.4.2);</li> <li>(b) When retrofitting insulation in exterior walls without wall underlay with drained/veneer cavities (see 5.4.3).</li> </ul>



Step	Action
	For steel-framed installations, insulation shall be capable of supporting itself <i>in situ</i> except where mechanical fixing can be applied. Mechanical fixings that can be applied to steel framing include gluing or using staple guns with hardened staples.  For masonry walls, only install insulation products intended for use over masonry walls.
4.	Insulation that is to be installed around recessed luminaires shall be compatible with those luminaires. See section 4 for further details.
5.	In a wall that will remain unlined (that is, where the insulation will remain exposed to the interior space after completion of all building work) check with the manufacturer that the insulation has a minimum performance of Group Number 3 as defined in Appendix A of C/VM2, Verification Method 2 for Building Code clauses C1 – C6.
6.	Foamed plastic insulation installed in lined walls shall comply with the flame propagation criteria as specified in AS 1366. Check with the insulation manufacturer.

**5.2.5 Minimum clearances for hot inbuilt appliances in walls**

For minimum clearances from hot inbuilt appliances in walls, follow the manufacturer’s instructions for the appliance and the insulation product. Where the manufacturer’s instructions for the appliance are unknown, the following clearances shall be left.

**Gas appliances** Where the manufacturer’s instructions are unknown, leave clearances of 200 mm from the exposed flame of gas appliances (such as gas hobs and radiant heaters) and leave clearances of 75 mm from the flues of gas appliances (stoves, water heaters, and space heaters). For clearances from uncommon gas appliances such as pottery kilns and pool heaters refer to AS/NZS 5601.1.

NOTE – These default clearances may be reduced when non-combustible insulation is used or when non-combustible material protects the wall being insulated. Refer to AS/NZS 5601.1 for detailed requirements for clearances from gas appliances or use the heating appliance manufacturer’s instructions.

**Oil-fired appliances** Where the manufacturer’s instructions are unknown, leave clearances of 230 mm from the flues of oil-fired appliances.

NOTE – These default clearances may be reduced when non-combustible insulation is used or when non-combustible material protects the wall being insulated. Refer to AS 1691 for detailed requirements for clearances from oil-fired appliances or use the heating appliance manufacturer’s instructions.

**Open fires** Where the manufacturer’s instructions are unknown, leave clearances of 50 mm from brick chimneys and leave clearances of 200 mm from the fireplace opening.

NOTE – These default clearances may be reduced when non-combustible insulation is used. Refer to the NZBC Acceptable Solution for Protection from Fire, C/AS1 for detailed requirements.

**Recessed luminaires**

Follow 4.2.3.

**Solid fuel appliances**

Where the manufacturer's instructions are unknown, leave clearances of 600 mm from built-in solid fuel burners. Leave clearances from the flue of any solid fuel burners (that penetrates a wall) of 600 mm or four times the flue diameter, whichever is greater. A guard shall be provided to maintain these clearances.

NOTE – These default clearances may be reduced when non-heat-sensitive (that is, allowable service temperature is greater than 150°C as determined in accordance with AS/NZS 2918) insulation material is used or when heat shields are installed. Clearance details are given in AS/NZS 2918 or as per the heating appliance manufacturer's instructions.

**5.2.6 Avoiding condensation in unlined walls**

To avoid damage from condensation, insulated walls between conditioned and unconditioned spaces and between conditioned spaces and outside shall be lined on the interior; that is, on the conditioned side of the insulation.

**5.2.7 Steel-framed walls**

Insulation shall be installed into the flange of the steel framed C-section members.

Steel-framing elements not accessible for insulation should be pre-insulated by the frame manufacturer. These include lintels, double studs, and so on.

Personnel responsible for the construction of steel-framed buildings should be encouraged to minimise the length of all screws used to reduce the risk of puncturing or compressing insulation materials.

**5.3 Timber/steel-framed walls with wall underlay****5.3.1 Installation methods**

The installation methods described in 5.3.2 and 5.3.3 apply to external walls with a wall underlay that is in good condition, and to internal walls.

In new construction the insulation shall not be fitted until the external wall cladding is complete. The insulation is then installed from the inside of the building.

When retrofitting from the inside following this method, a wall underlay and cladding system shall be already in place and in good condition (that is, providing a continuous barrier to water). Otherwise see 5.4 for guidance on retrofitting insulation in walls without wall underlay.

If retrofitting the insulation from the outside, a new wall cladding system shall be installed immediately after the insulation is fitted or other suitable protection such as temporary tarpaulins shall be provided until the new cladding system is installed.

Steel-framing elements not accessible for insulation should be pre-insulated by the frame manufacturer. These include lintels, double studs, and so on.

**5.3.2 Installing blanket and segments (including semi-rigid)**

The following steps shall be taken when installing blanket and segments (including semi-rigid).

Step	Action
1.	<p>Make sure all insulation products are protected from the weather before, during, and after installation. Make sure fitted insulation is undamaged and dry.</p> <p>In new constructions, do not fit the insulation until external wall cladding is complete.</p> <p>When retrofitting from the inside, make sure a wall underlay and cladding system is already in place and in good condition (that is, providing a continuous barrier to water).</p> <p>If retrofitting the insulation from the outside, install a new wall cladding system immediately after the insulation is fitted, or provide other suitable protection such as temporary tarpaulins. Confirm with the cladding installer that they are aware of the requirement to keep the insulation dry.</p> <p>The new cladding system shall meet NZBC requirements and wherever possible should meet industry best practice, including correct installation of wall underlay and flashings.</p>
2.	Follow the manufacturer’s installation instructions.
3.	Depending on the manufacturer’s instructions, tear or cut the insulation about 5 mm greater than the space available against a firm, straight surface.
4.	<p>Push the insulation into the wall space. Make sure there are no gaps around the outer edges of the insulation and no folds or tucking in. For steel framing, fit the insulation into the C-section members.</p> <p>Where insulation pieces are butted together make sure there are no gaps between them.</p>
5.	Installed insulation should fill the entire thickness of the cavity without undue compression of the insulation (see Figure 16). Where the depth of the insulation does not fill the cavity, fit the insulation flush with the interior side of the framing.
6.	<p>Some products may either need to be supported on all six faces or fastened into place (see Figure 17), without undue compression of the product.</p> <p>Strapping may be installed horizontally at sufficient intervals to support the insulation until the internal lining or cladding system is installed.</p> <p>Strapping is only acceptable as a permanent means of support on the unconditioned side of internal walls and if installed at no greater than 300 mm centres.</p>
7.	<p>Fit insulation snugly around cables and pipes, minimising gaps, tucks, or folds in the insulation while taking care not to damage the cables and pipes.</p> <p>For cables and small-diameter pipes this can be achieved by marking the position of cables on the insulation, cutting through part of the insulation, and placing it around the pipes or wires.</p> <p>Cut insulation to fit around switch and socket boxes without undue compression.</p>
8.	Use offcuts from the insulation product to fill small gaps between framing.

Step	Action
9.	Continue cutting and fitting the insulation, working along the walls until all of the exterior walls and any required interior wall spaces are filled from top to bottom plates.
10.	Provide a product label and installer information to the building owner or other authorised person in accordance with 2.7.
11.	Inspect the finished job to ensure there are no gaps, tucking in, or folds.



Figure 16 – Insulation fitted into a steel-framed wall



Figure 17 – Stapling blanket

5.3.3 Installing rigid sheet insulation

The following steps shall be taken when installing rigid sheet insulation.

Step	Action
1.	<p>Make sure all insulation products are protected from the weather before, during, and after installation. Make sure fitted insulation is undamaged and dry.</p> <p>In new constructions the insulation shall not be fitted until external wall cladding is complete.</p> <p>When retrofitting from the inside, make sure a wall underlay and cladding system is already in place and in good condition (in case of any leaks through the exterior cladding by providing a continuous barrier to water).</p> <p>If retrofitting the insulation from the outside, install the new wall cladding system immediately after the insulation is fitted, or provide other suitable protection such as temporary tarpaulins. Confirm with the cladding installer that they are aware of the requirement to keep the insulation dry.</p> <p>The new cladding system shall meet NZBC performance requirements and wherever possible should meet industry best practice, including correct installation of wall underlay and flashings.</p>
2.	Follow the manufacturer's installation instructions.
3.	Cut the insulation about 2 mm greater than the space available against a firm, straight surface.
4.	Push the insulation into the wall space, making sure no gaps are left around the outer edges of the insulation and where insulation pieces are butted together. For steel framing fit the insulation into the C-section members, ensuring there are no gaps left between the insulation and steel.
5.	Installed insulation should fill the entire thickness of the cavity. Where the depth of the insulation does not fill the cavity, fit the insulation flush with the internal side of the framing.
6.	<p>Cut the insulation around or between cables and pipes, making sure no gaps are left in the insulation while taking care not to damage the cables and pipes. Avoid contact between cables and polystyrene insulation products. See 3.5 for details.</p> <p>Where possible cut insulation to fit around and behind switch and socket boxes, shower mixers, and other equipment fitted within the wall cavity.</p>
7.	Continue cutting and fitting the insulation, working along the walls until all of the exterior walls and any required interior wall spaces are filled from top to bottom plates.
8.	At the end of the installation check and repair any visible gaps by using insulation offcuts or foam sealant, including gaps between framing, around doors, windows, or double-stud cavities.
9.	Provide a product label and installer information to the building owner or other authorised person in accordance with 2.7.
10.	Inspect the finished job to ensure there are no gaps.

## 5.4 Timber/steel-framed walls without wall underlay

### 5.4.1 Methods for retrofitting insulation in exterior walls without wall underlay

This section provides guidance for retrofitting wall insulation from the inside where there is no wall underlay or where the existing wall underlay is in poor condition.

If a good condition wall underlay is already in place or will be installed following the insulation installation, see 5.3 for guidance.

For external walls without a functional wall underlay the following two methods may be adopted.

#### (a) Method 1 – Maintaining a gap between insulation and cladding

With this method, a gap is left between the insulation and the back of the cladding to ensure that the drainage path on the back of the cladding is maintained and that the insulation does not come into contact with the cladding.

#### (b) Method 2 – Retrofitting inserts of wall underlay before insulation installation

With this method, inserts of wall underlay are fitted from the interior before insulation material is installed in the wall cavity (see Figure 18). The folded edges of the wall underlay inserts shall extend to the internal edge of the wall framing. Staple the wall underlay taut to the timber framing, with staples in each corner and at about 100 mm centres.

NOTE – NZBC Acceptable Solution for External Moisture E2/AS1 contains information on the properties of wall underlays. Consult it to help choose an appropriate wall underlay.

#### C5.4.1

*A wall underlay installed in accordance with Method 2 will help protect the insulation from absorbing or transferring water from the backside of the wall cladding. However, wall underlay installed in this manner could reduce the water management ability of the existing wall. Leaving a 20 mm minimum gap between the back of the cladding and the wall underlay inserts or insulation is unlikely to compromise the water management ability of the wall.*

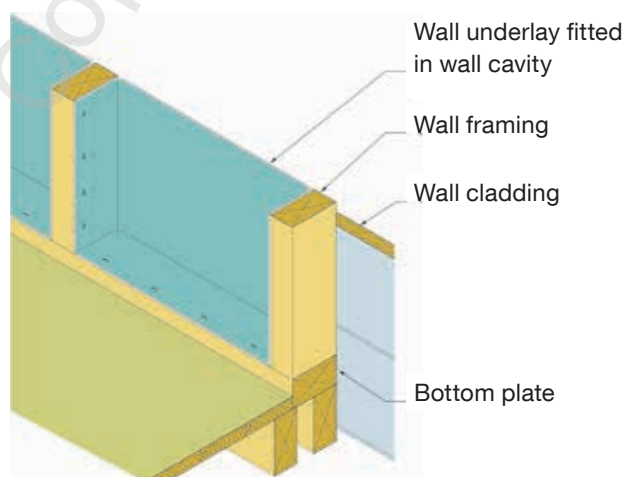


Figure 18 – Retrofitting wall underlay

**5.4.2 Retrofitting insulation in exterior walls without wall underlay with direct-fixed claddings**

The following steps shall be taken when retrofitting insulation into existing framed walls with direct-fixed claddings without wall underlay.

Step	Action
1.	Make sure all insulation products are protected from the weather before, during, and after installation. Make sure fitted insulation is undamaged and dry.
2.	Follow the manufacturer's installation instructions.
3a.	<p>Method 1 (see 5.4.1)</p> <p>Leave a gap between the insulation and the back of the cladding. This gap ensures that the drainage path on the back of the cladding is maintained. In the absence of the manufacturer's instructions on how to maintain this gap, use the following procedure.</p> <p>(a) Use only rigid sheet or semi-rigid insulation that is at least 20 mm thinner than the framing width (for example, for walls with 90 mm framing the insulation product shall be no thicker than 70 mm). This will allow a gap of at least 20 mm between the insulation and the external cladding. Some semi-rigid insulation products can take time to reach full loft (size), check the nominal insulation thickness on the product label;</p> <p>(b) Before fitting the insulation, install strapping horizontally at intervals no greater than 300 mm centres by stapling into the sides of the wall studs (see Figure 19). Install the strapping in a way that prevents the insulation moving towards the cladding and ensures a 20 mm minimum gap between the insulation and cladding will be maintained;</p> <p>(c) Alternatively, for rigid sheet insulation only, a rigid plastic or metal angle may be fixed to the wall framing in a way that prevents the insulation from moving towards the cladding and ensures a 20 mm minimum gap between the insulation and cladding is maintained.</p>
3b.	<p>Method 2 (see 5.4.1)</p> <p>Fit inserts of wall underlay to the entire exterior wall area to be insulated in accordance with 5.4.1(b).</p>
4.	Depending on the manufacturer's instructions, tear or cut the semi-rigid insulation about 5 mm greater than the space available against a firm, straight surface. Cut rigid sheet insulation about 2 mm greater than the space available against a firm, straight surface.
5.	<p>Push the insulation into the wall space.</p> <p>There shall be no gaps around the outer edges of the insulation and no folds or tucking in. Where insulation pieces are butted together there shall be no gaps between them.</p> <p>For steel framing fit the insulation into the C-section members.</p>
6.	Fit the insulation flush with the internal side of the framing.
7.	Some products may need to be supported by being fastened into place, without undue compression of the product. Strapping may be installed horizontally at sufficient intervals to support the insulation until the internal lining is installed.



Step	Action
8.	<p>Fit insulation snugly around cables and pipes, minimising gaps, tucks, or folds in the insulation while taking care not to damage the cables and pipes. For cables and small-diameter pipes this can be achieved by marking the position of cables on the insulation, cutting through part of the insulation, and placing it around the pipes or wires. Cut insulation to fit around switch and socket boxes without undue compression.</p> <p>Cut rigid sheet insulation around or between cables and pipes, minimising gaps in the insulation while taking care not to damage the cables and pipes. Avoid contact between cables and polystyrene insulation products. See 3.5 for details. Where possible cut insulation to fit around and behind switch and socket boxes, shower mixers, and other equipment fitted within the wall cavity.</p>
9.	Use insulation offcuts to fill small gaps between framing.
10.	Continue fitting the insulation until all of the exterior walls are filled from top to bottom plates.
11.	Provide a product label and installer information to the building owner or other authorised person in accordance with 2.7.
12.	Inspect the finished job to ensure there are no gaps, tucking in, or folds. Repair any visible gaps by using insulation offcuts or, if using rigid sheet insulation, foam sealant.



NOTE – The figure illustrates the way of strapping the wall before insulation is retrofitted in walls without wall underlay (Method 1). Ignore the wall underlay shown in the photo.

**Figure 19 – Installing strapping horizontally**

**5.4.3 Retrofitting insulation in exterior walls without wall underlay with drained/veneer cavities**

The following steps shall be taken when retrofitting insulation into existing framed walls with drained or veneer cavities without wall underlay.

Step	Action
1.	Make sure all insulation products are protected from the weather before, during, and after installation. Make sure fitted insulation is undamaged and dry.
2.	Make sure the insulation product is no thicker than the structural wall framing (usually 90 – 100 mm). NOTE – Some insulation products can take time to reach full loft (size) – check the nominal insulation thickness on the product label.
3.	Follow the manufacturer’s installation instructions.
4.	Depending on the manufacturer’s instructions, tear or cut the insulation about 5 mm greater than the space available against a firm, straight surface. Cut rigid sheet insulation about 2 mm greater than the space available against a firm, straight surface.
5a.	Method 1 (see 5.4.1) Make sure the insulation does not protrude beyond the outside of the wall framing into the drained/veneer cavity. In the absence of the manufacturer’s instructions on how to prevent the insulation protruding beyond the outside of the wall framing and into the drained/veneer cavity, use the following procedure. (a) Use only rigid sheet or semi-rigid insulation; (b) Before fitting the insulation, install strapping horizontally at intervals no greater than 300 mm centres by stapling into the sides of the wall studs as shown in Figure 19; (c) The strapping shall be installed to prevent the insulation from protruding beyond the outside of the wall framing into the drained/veneer cavity; (d) Alternatively, for rigid sheet insulation only, a rigid plastic or metal angle may be fixed to the wall framing in a way that prevents the insulation moving into the drained veneer/cavity.
5b.	Method 2 (see 5.4.1) Fit inserts of wall underlay to the entire exterior wall area to be insulated in accordance with 5.4.1(b).
6.	Push the insulation into the wall space. There shall be no gaps around the outer edges of the insulation and no folds or tucking in. Where insulation pieces are butted together there shall be no gaps between them. For steel framing fit the insulation into the C-section members.
7.	Fit the insulation flush with the internal side of the framing.
8.	Some products may need to be supported by being fastened into place, without undue compression of the product. Strapping may be installed horizontally at sufficient intervals to support the insulation until the internal lining is installed.

Step	Action
9	Fit semi-rigid insulation snugly around cables and pipes, minimising gaps, tucks, or folds in the insulation while taking care not to damage the cables and pipes. For cables and small-diameter pipes this can be achieved by marking the position of cables on the insulation, cutting through part of the insulation, and placing it around the pipes or wires. Cut insulation to fit around switch and socket boxes without undue compression.  Cut rigid sheet insulation around or between electrical cables and pipes, minimising gaps in the insulation while taking care not to damage the cables and pipes. Avoid contact between electrical cables and polystyrene insulation products. See 3.5 for details. Where possible cut insulation to fit around and behind switch and socket boxes, shower mixers, and other equipment fitted within the wall cavity.
10.	Use offcuts from the insulation product to fill small gaps between framing.
11.	Continue cutting and fitting the insulation working along the walls until all of the exterior walls are filled from top to bottom plates.
12.	Provide a product label and installer information to the building owner or other authorised person in accordance with 2.7.
13.	Inspect the finished job to ensure there are no gaps, tucking in, or folds. Repair any visible gaps by using insulation offcuts or, if using rigid sheet insulation, foam sealant.

## 5.5 Loose-fill wall insulation

### 5.5.1 General

The purpose of 5.5 is to highlight critical aspects of installing loose-fill wall insulation. It does not provide a step-by-step installation process. The special considerations in section 2 and 5.2 shall be read in conjunction with the following comments and actions.

The following situations are excluded from the scope of this standard:

- (a) Expanding *in situ* foams;
- (b) Insulation in ventilation cavities of walls, including brick veneer cavities;
- (c) Insulation in the cavity of double brick walls;
- (d) Loose-fill insulation in walls without a wall underlay, or where the existing wall underlay is in poor condition.

### 5.5.2 Insulation material

Loose-fill insulation materials are commonly manufactured off site and the finished product is formed on site. Because of this, compliance (in accordance with AS/NZS 4859.1) cannot be demonstrated solely through a manufacturing quality system or an audit process. It is important that the installer is trained and experienced with loose-fill products, the installation system is well proven, and care is taken to follow the installation methodology to ensure good performance of loose-fill wall insulation.

**5.5.3 Building assessment prior to installation**

Loose-fill insulation is installed into wall cavities that cannot easily be sighted prior to installation. Therefore it is critical that a thorough assessment is made to determine if a wall is suitable to install loose-fill insulation into, considering such things as:

- (a) Weathertightness risk assessment;
- (b) Age of the house;
- (c) The presence and condition of wall underlay;
- (d) Pre-existing defects in the cladding and remediation;
- (e) Moisture readings;
- (f) Repair of injection holes and repainting of external wall.

When dropped soffits are present, advise building owners whether the wall area above the soffit will be insulated.

**5.5.4 Building consent**

The building consent application needs to show how the installation will comply with the NZBC and that it will not adversely affect the performance of the existing building (see 2.3).

Information provided in a building consent application needs to be tailored to the particular insulation product, installation system and the building that is being retrofitted. An application should include the following:

- (a) An assessment of the building for suitability to install wall insulation;
- (b) Installation methodology;
- (c) A floor plan and elevations (or photos) showing which external walls are to be insulated, external windows and doors, location of smoke alarms and of heating appliances;
- (d) Locations and values of any measurements taken, for example moisture readings.

**5.5.5 Installing loose-fill wall insulation**

The following actions shall be taken when installing loose-fill wall insulation.

Step	Action
1.	Use qualified installers and an installation system that has a proven track record.
2.	Ensure a building consent has been obtained to do the work or that the Building Consent Authority has given specific approval that a building consent is not required (it is exempt).
3.	Install insulation as detailed in the building consent or in accordance with any conditions of an approval by the territorial authority to install without a building consent.  NOTE – Care should be taken to not damage electrical wiring and plumbing when injection holes are drilled.

Step	Action
4.	Inspect the wall cavity prior to the installation of any insulation, progressively in parts of the walls where injection holes have been drilled (see 5.2.2 and 5.2.3).
5.	Inspect the wall after insulation has been injected, and check for leakage into cupboards, roof spaces, and the subfloor.
6.	Check, by calculation or otherwise, the installed insulation achieves the required density.
7.	Provide an installation certificate, or equivalent, to the building owner or other authorised person (as per 2.7) that includes the following information: <ul style="list-style-type: none"> <li>(a) Date of installation;</li> <li>(b) Material used;</li> <li>(c) Name and address of manufacturer and installer;</li> <li>(d) Declared R-value;</li> <li>(e) Design density (kg/m<sup>3</sup>), thickness (mm) and R-value (m<sup>2</sup>.°C/W) (information from suppliers);</li> <li>(f) Installed thickness (mm);</li> <li>(g) Net wall area (m<sup>2</sup>); and</li> <li>(h) Net weight of the installed insulation (kg) (that is, the weight of each pack (kg) and total number of packs used).</li> </ul> Make sure the certificate is signed by the installer verifying the above information is correct.

## 5.6 Masonry walls

### 5.6.1 Installing insulation to the inside of masonry walls

Clauses 5.6.2 and 5.6.3 describe the installation of insulation to the inside of masonry walls. Only insulation products intended for use over masonry walls shall be installed.

### 5.6.2 Installing segments, rigid and semi-rigid insulation from the interior

The following steps shall be taken when installing segments, rigid and semi-rigid insulation to the inside of masonry walls.

Step	Action
1.	Make sure all insulation products are protected from the weather before, during, and after installation. Make sure fitted insulation is undamaged and dry.
2.	Follow the manufacturer's installation instructions.
3.	Friction-fit insulation between battens against the masonry wall.
4.	If required secure the insulation until the wall linings are in place.
5.	Make sure there are no gaps, tucking in, or folds.



Step	Action
6.	Cut the insulation around or between electrical cables and pipes, making sure no gaps are left in the insulation while taking care not to damage the cables and pipes. Avoid contact between electrical cables and polystyrene insulation products (see 3.5 for details).  Cut insulation to fit around switch and socket boxes without undue compression.
7.	Continue cutting and fitting the insulation until all the walls are filled from top to bottom.
8.	Inspect the finished job to ensure there are no gaps, tucking in, or folds. Repair any visible gaps by using insulation offcuts or, if using rigid sheet insulation, foam sealant.
9.	Provide a product label and installer information to the building owner or other authorised person in accordance with 2.7.

### 5.6.3 Installing blanket insulation from the interior

The following steps shall be taken when installing blanket insulation over the inside of masonry walls.

Step	Action
1.	Make sure all insulation products are protected from the weather before, during, and after installation. Make sure fitted insulation is undamaged and dry.
2.	Follow the manufacturer's installation instructions.
3.	Install the blanket hard up against the masonry between battens and drape it down to the bottom plate. Installed insulation should fill the entire thickness of the cavity without undue compression of the insulation. Some products may require securing at the top of the wall, refer to manufacturers' installation instructions.
4.	It may be necessary to secure the insulation temporarily until the wall linings are in place.
5.	Make sure there are no gaps, tucking in, or folds. Make sure blanket insulation products that require securing at the top have no joins and are continuous inside the framed cavity.
6.	Cut the insulation around or between electrical cables and pipes, making sure no gaps are left in the insulation while taking care not to damage the cables and pipes. Avoid contact between electrical cables and polystyrene insulation products. See 3.5 for details.
7.	Continue cutting and fitting the insulation until all the walls are filled from top to bottom.
8.	Inspect the finished job to ensure there are no gaps, tucking in, or folds. Repair any visible gaps by using insulation offcuts.
9.	Provide a product label and installer information to the building owner or other authorised person in accordance with 2.7.

## SECTION 6

# CEILINGS AND ROOFS

- 6.1 General
- 6.2 Special considerations
- 6.3 Segments and blankets insulation – unlined ceilings
- 6.4 Segments and blankets insulation – lined ceilings
- 6.5 Rigid sheet insulation – unlined and lined ceilings
- 6.6 Loose-fill insulation – lined ceilings

Copyright Standards New Zealand

Copyright Standards New  
Zealand



## 6 CEILINGS AND ROOFS

### 6.1 General

This section provides guidance for installing insulation in ceilings and shall be read in conjunction with sections 1 to 4.

### 6.2 Special considerations

#### 6.2.1 Inspections before installing insulation in existing ceilings

Before installing insulation the following checks shall be made by the insulation installer or alternatively the insulation installer shall confirm that these checks have been made.

Step	Action
1.	Check for health and safety hazards on site. Appendix B contains health and safety information.
2.	Make sure all materials are dry and cleaned of any contaminants, including mould and asbestos. Make sure any damp, wet, or unsanitary existing insulation is removed before insulation is fitted. Follow WorkSafe New Zealand guidelines for identification and removal of asbestos.
3.	Check the entire roof area for signs of water damage (roof leaks, condensation, leaking pipes, rot, or mould), or borer. If in doubt, consult a suitably qualified building surveyor before insulation is installed. Make sure any such deficiencies are remedied by a licensed building practitioner before installing ceiling insulation.
4.	If a green/black-coloured mould is found, stop work immediately. Notify the building owner or other authorised person that a testing lab will need to identify if the mould is a toxic variety (stachybotrys).
5.	Remove non-toxic mould by thoroughly cleaning the surfaces with either a proprietary mould remover or a household bleach solution (100 ml of bleach per 1 litre of water). Allow surfaces to dry thoroughly.  The building owner will need to have a specialist contractor remove toxic mould (stachybotrys) before insulation installation continues.
6.	Refer all incidences of rot or borer to the building owner for appropriate remediation before installing insulation.



Step	Action
7.	<p>For existing skillion roofs:</p> <ul style="list-style-type: none"> <li>(a) The moisture content of timber framing should be 20% or less before insulation is installed;</li> <li>(b) Make sure steel-frame rafters have a thermal break installed between roofing/purlins and the rafter;</li> <li>(c) Where roofing is not being replaced, check the presence and condition of roof underlay. If the existing skillion roof underlay is not in good condition then insulation should not be installed;</li> <li>(d) Confirm that a registered electrician has inspected all wiring inside the roof cavity and has confirmed that all wiring is in good condition and suitable for being surrounded by thermal insulation. Rewiring or installing circuit breakers may be necessary where wiring is inadequately rated.</li> </ul>
8.	<p>Identify areas where clearances may be required, including:</p> <ul style="list-style-type: none"> <li>(a) Built-in appliances or enclosures containing electrical equipment (see 3.2);</li> <li>(b) Recessed or surface-mounted luminaires (see 4.2 and 4.3);</li> <li>(c) Independent controlgear (see 4.4);</li> <li>(d) Fan/heat/light units (see 4.6);</li> <li>(e) Ventilation systems (see 6.2.11);</li> <li>(f) Unducted mechanical fan units (see 6.2.12);</li> <li>(g) Unducted passive ceiling vents that remain functional (see 6.2.13);</li> <li>(h) Chimneys and flues (see 6.2.14);</li> <li>(i) Under concrete header tanks in climate zone 3 and in locations prone to freezing (see 6.2.5).</li> </ul> <p>Inform the building owner or other authorised person of areas that cannot be insulated, including where and why clearances will be left.</p>
9.	<p>In climate zone 3 (see Appendix D for a map of New Zealand climate zones) and locations prone to freezing, identify any hot and cold water pipes in the roof space that will need to be insulated (see 6.2.4).</p>
10.	<p>Check if foil insulation has been installed as a roof underlay (see 6.2.7).</p>
11.	<p>Identify any recessed or dropped spaces or skylight shafts that require wall insulation product (see 6.2.8 and 6.2.17).</p>
12.	<p>Check for any space restrictions to maintain insulation clearance to roofing and roof underlay (see 6.2.10). If an insulation product has already been selected, check that the product has the correct nominal thickness for maintaining this clearance. The nominal thickness and width are specified on the pack label of the insulation product. If the specified insulation product will not allow for the 25 mm clearance to be maintained, consult the designer/specifier on the choice of product before insulation is installed.</p>
13.	<p>If insulation is to be installed between ceiling joists or rafters, choose an insulation product of the correct width for the joist or rafter spacing.</p>
14.	<p>In steel-framed roofs also fit insulation inside the bottom truss chord (see Figure 20). Insulation products fitted in the bottom truss chord should have the same R-value as the rest of the ceiling insulation being installed.</p>

### 6.2.2 Inspections before installing insulation in new ceilings

Before installing insulation, the following checks shall be made by the insulation installer or alternatively the insulation installer shall confirm that these checks have been made.

Step	Action
1.	Check for health and safety hazards on site. Appendix B contains health and safety information.
2.	Make sure all cavities and materials are dry and cleaned of any waste or contaminants.
3.	Make sure the moisture content of timber framing is 20% or less before insulation is installed. Check steel-frame bottom truss chords to make sure there is no water ponding in them.
4.	Make sure steel-frame trusses have a thermal break in place between the truss and outside wall framing (see Figure 20). Make sure steel-frame rafters in skillion roofs have a thermal break installed between roofing/purlins and the rafter (see Figure 21).
5.	Identify areas where clearances may be required, including: <ul style="list-style-type: none"> <li>(a) Built-in appliances or enclosures containing electrical equipment (see 3.2);</li> <li>(b) Recessed or surface-mounted luminaires (see 4.2 and 4.3);</li> <li>(c) Independent controlgear (see 4.4);</li> <li>(d) Fan/heat/light units (see 4.6);</li> <li>(e) Ventilation systems (see 6.2.11);</li> <li>(f) Unducted mechanical fan units (see 6.2.12);</li> <li>(g) Unducted passive ceiling vents that remain functional (see 6.2.13);</li> <li>(h) Chimneys and flues (see 6.2.14);</li> <li>(i) Under concrete header tanks in climate zone 3 and in locations prone to freezing (see 6.2.5).</li> </ul> Inform the building owner or other authorised person of areas that cannot be insulated, including where and why clearances will be left.
6.	In climate zone 3 (see Appendix D for the map of New Zealand climate zones) and locations prone to freezing, identify any hot and cold water pipes in the roof space that will need to be insulated (see 6.2.4).
7.	Identify any recessed or dropped spaces or skylight shafts that require wall insulation product (see 6.2.8 and 6.2.17).
8.	Check for any space restrictions to maintain insulation clearance to roofing and roof underlay (see 6.2.10). If an insulation product has already been selected, check that the product has the correct nominal thickness for maintaining this clearance. The nominal thickness and width are specified on the pack label of the insulation product. If the specified insulation product will not allow for the 25 mm clearance to be maintained, consult the designer or specifier on the choice of product before insulation is installed.
9.	If insulation is to be installed between ceiling joists or rafters, choose an insulation product of the correct width for the joist or rafter spacing.

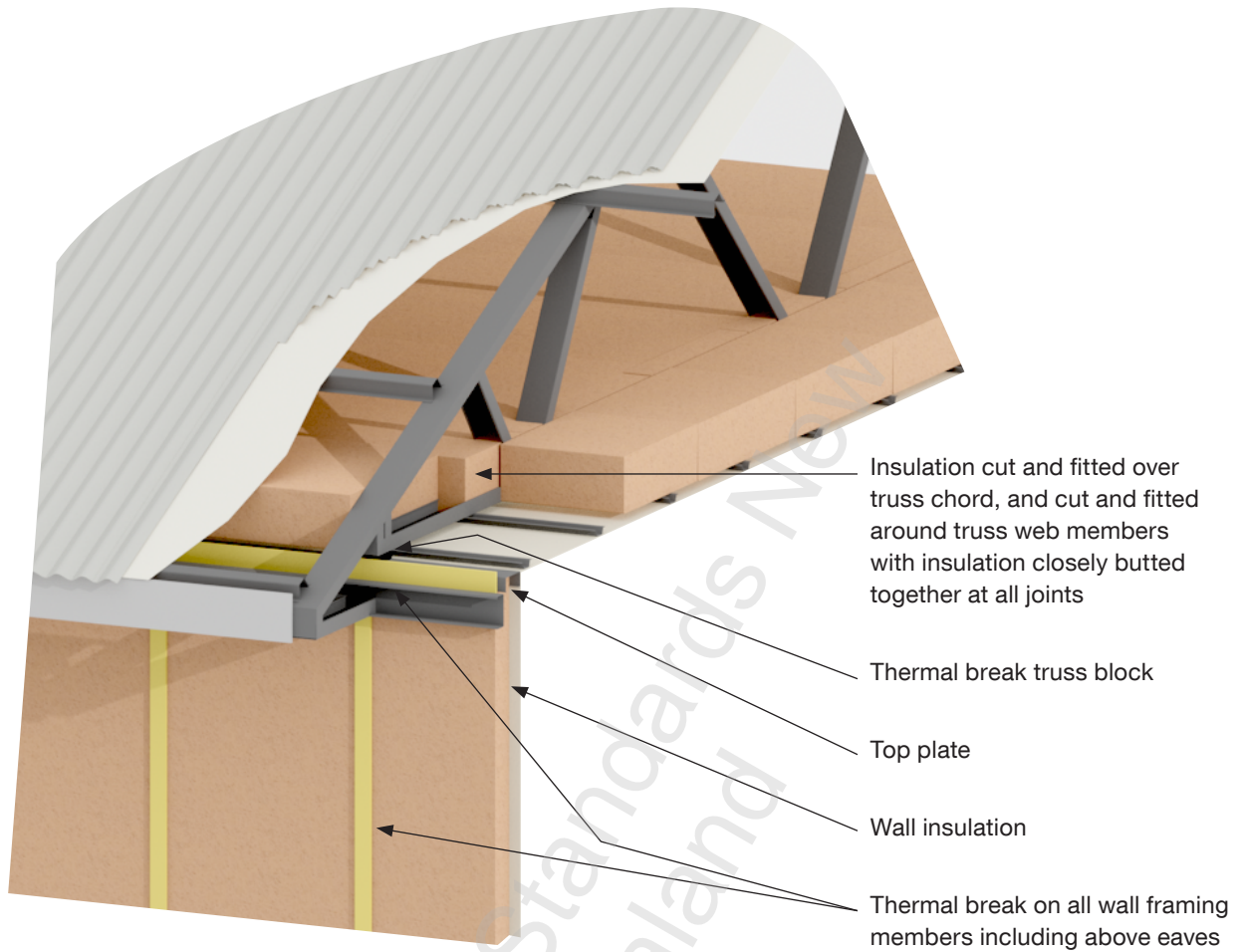


Figure 20 – Steel-framed truss roof

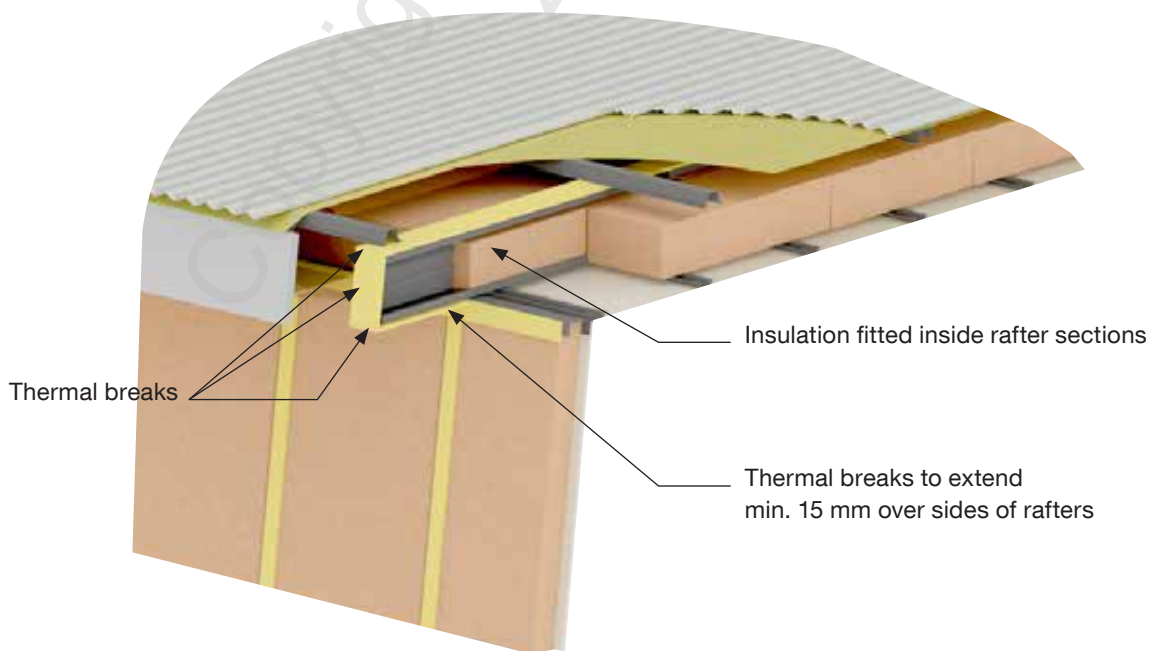


Figure 21 – Steel-framed skillion roof

### 6.2.3 Choosing a ceiling insulation product

The following steps shall be taken when choosing a ceiling insulation product.

Step	Action
1.	Ensure the insulation product complies with AS/NZS 4859.1. Refer to the product label of the insulation product for a compliance statement.
2.	Ensure the product is fit-for-purpose and designed for insulating ceilings or roofs. Refer to the manufacturer's instructions and ensure it complies with consent documents.
3.	For skillion and low-slope roofs, check the insulation product has the correct nominal thickness (see 6.2.10).  If insulation is to be installed between ceiling or roof framing, check the insulation product has the correct width to fit between the framing without gaps, tucks, or folds.  If insulation is to be installed over ceiling joists or trusses, use blanket type or loose-fill insulation, except where segments are installed as a second layer over existing insulation, which consistently has at least the same height as the top of the ceiling joists or truss chords.
4.	If insulation is to be installed near recessed luminaires, check the insulation product is compatible with the type of recessed luminaire (see 4.2).
5.	In situations where insulation is going to form a surface lining material (remain unlined) it shall comply with the relevant Group Number specified in NZBC Clause C3. Group Numbers are defined in Appendix A of C/VM2, Verification Method 2 for Building Code clauses C1 – C6.
6.	Foamed plastic insulation installed in lined ceilings shall comply with the flame propagation criteria as specified in AS 1366. Check with the insulation manufacturer.

### 6.2.4 Insulating cold and hot water pipes in ceiling spaces

In climate zone 3 (see Appendix D) and locations prone to freezing, the entire length of all water pipes protruding above ceiling insulation shall be insulated in accordance with section 9.

#### **C6.2.4**

*Installing insulation reduces the rate of heat loss through the ceiling. In houses situated in areas subject to temperatures below 0°C, introducing ceiling insulation can cause freezing of water pipes protruding above the insulation.*

**6.2.5 Avoiding damage to header tanks in ceiling spaces**

In climate zone 3 (see Appendix D) and in locations prone to freezing, the ceiling directly underneath a concrete header tank that is still in use shall not be insulated. Otherwise water in the tank may freeze and the tank may crack.

If access allows, ceiling insulation shall be installed under header tanks in the following situations:

- (a) Where the header tank is not made of concrete or another brittle material;
- (b) Where a concrete header tank is no longer in use; or
- (c) In locations not prone to freezing in climate zones 1 and 2, regardless of the header tank type.

**6.2.6 Buildings with ventilated cavities in walls**

In buildings with suspended floors and a ventilated cavity in walls (such as brick veneer or double brick walls) introduction of ceiling insulation can also result in condensation forming on the roof underlay or exposed roofing material. This can be due to excessive moisture content in the subfloor air that rises up the ventilation cavity and rapidly cools off in the roof space, forming condensation. Such buildings would benefit from an on-ground vapour barrier (see section 8).

**6.2.7 Roof or ceiling spaces with foil insulation**

Extreme caution shall be taken when working with and around existing foil insulation. Refer to NZECP 55 and Appendix B of this standard for important information on managing the electrical safety risks presented by foil insulation.

Insulation shall not be installed in a roof or ceiling space where foil insulation has been installed as a roof underlay. The foil insulation, when installed as a roof underlay, shall not be removed without consulting a licensed building practitioner or an otherwise suitably qualified person, and obtaining the consent of the building owner.

Foil insulation draped over ceiling joists shall be removed before insulation installation.

Where the foil insulation is not installed as a roof underlay nor draped over ceiling joists (for example, foil-backed plasterboard, foil attached to the underside of roof rafters, or foil installed under ceiling joists), the foil insulation may be left in place and the ceiling may be insulated.

**C6.2.7**

*It is not uncommon to find foil-based products used as roof underlay in existing houses. Such products do not meet the requirements of Table 2.3 of the NZBC Acceptable Solution for Extensive Moisture, E2/AS1, which requires absorbent roof underlays.*

*Insulating roof or ceiling spaces with foil insulation as roof underlay can result in condensation forming on the reflective surface, which in turn can cause water damage to the insulation, ceiling lining, and other parts of the building.*

### 6.2.8 Insulating recessed spaces (dropped ceilings)

Insulate down walls and across recessed ceilings such as:

- (a) Where these form part of the thermal envelope;
- (b) Internal walls in split-level houses where these form a wall into the ceiling space;
- (c) Exterior walls where the porch ceiling is lower than the internal ceiling;
- (d) Bathrooms and internal wardrobes.

### 6.2.9 Blocking off gaps between ceiling insulation and ceiling lining in roof spaces

Ceiling insulation installed over ceiling joists, truss chords or ceiling battens may result in an air gap between the insulation and the ceiling lining. Air flowing underneath the ceiling insulation significantly reduces its thermal performance. To prevent this air flow there shall be no open air pockets along all edges of ceiling insulation, including along the perimeter of the insulated ceiling area and where insulation clearances are required. Where insulation is installed in lined ceilings from within the roof space, acceptable ways of achieving this include:

- (a) Along the perimeter of the ceiling and around other edges of the insulation layer, for example around insulation clearances, fitting the insulation with full and continuous contact with the ceiling lining or wall top plate;
- (b) Along the perimeter of the ceiling and around other edges of the insulation layer, for example around insulation clearances, fitting pieces of insulation continuously between the ceiling insulation and the ceiling lining or wall top plate. Ceiling insulation shall overlay the blocking pieces by a minimum of 150 mm. For insulation installed over ceiling joists or truss chords the insulation pieces used for blocking shall have a thickness similar to the combined depth of joists or truss chords and ceiling battens. For insulation installed between ceiling joists or trusses the insulation pieces used for blocking shall have a thickness similar to the depth of ceiling battens.

### 6.2.10 Keeping insulation clear of roofing and roof underlays

A minimum gap of 25 mm shall be maintained between the insulation and the underside of the roofing and flexible roof underlay to prevent wicking of water into the insulation.

In pitched roofs a thinner insulation product shall be used in areas where the specified ceiling insulation is likely to come in contact with roof underlay (see Figure 22). Check the nominal thickness on the product label. If the nominal thickness of the specified insulation product does not allow for the 25 mm clearance, consult the personnel responsible for the construction site for alternative solutions. Figures 22, 23, 24, 25, and 26 are typical construction details. When using insulation products susceptible to over-lofting, ensure the required 25 mm clearance will be maintained over time.

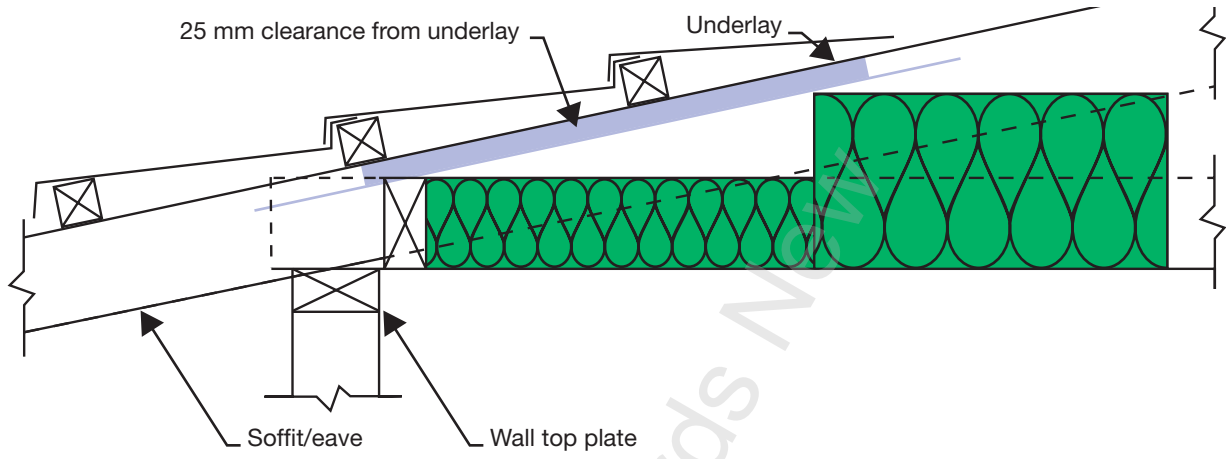


Figure 22 – Roof detail for a low-pitch roof

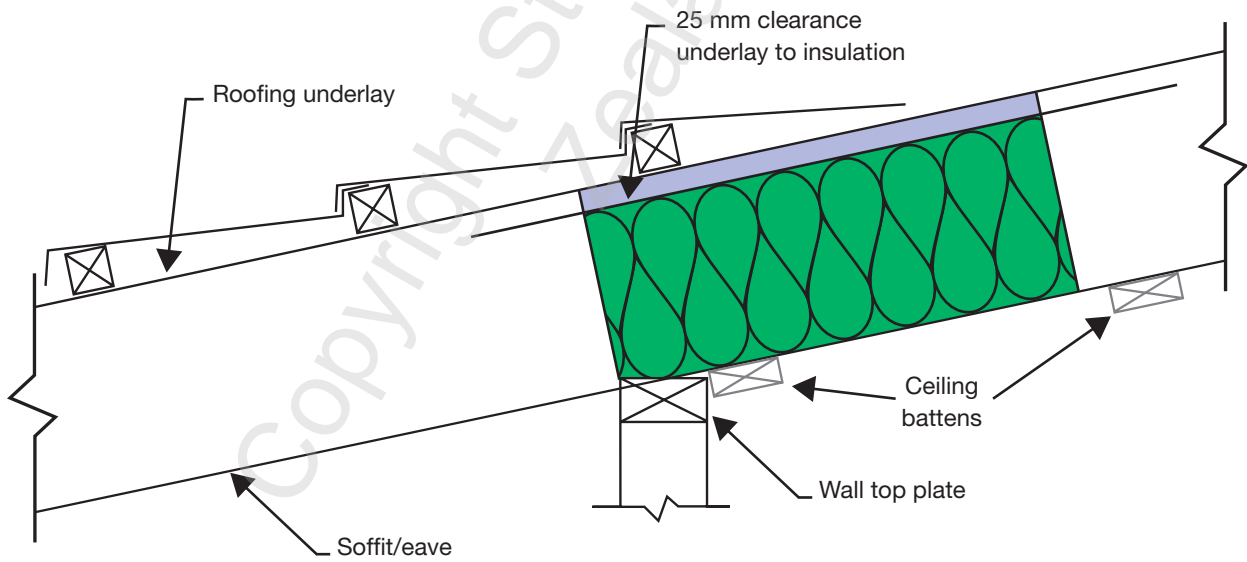


Figure 23 – Skillion roof with metal tile cladding



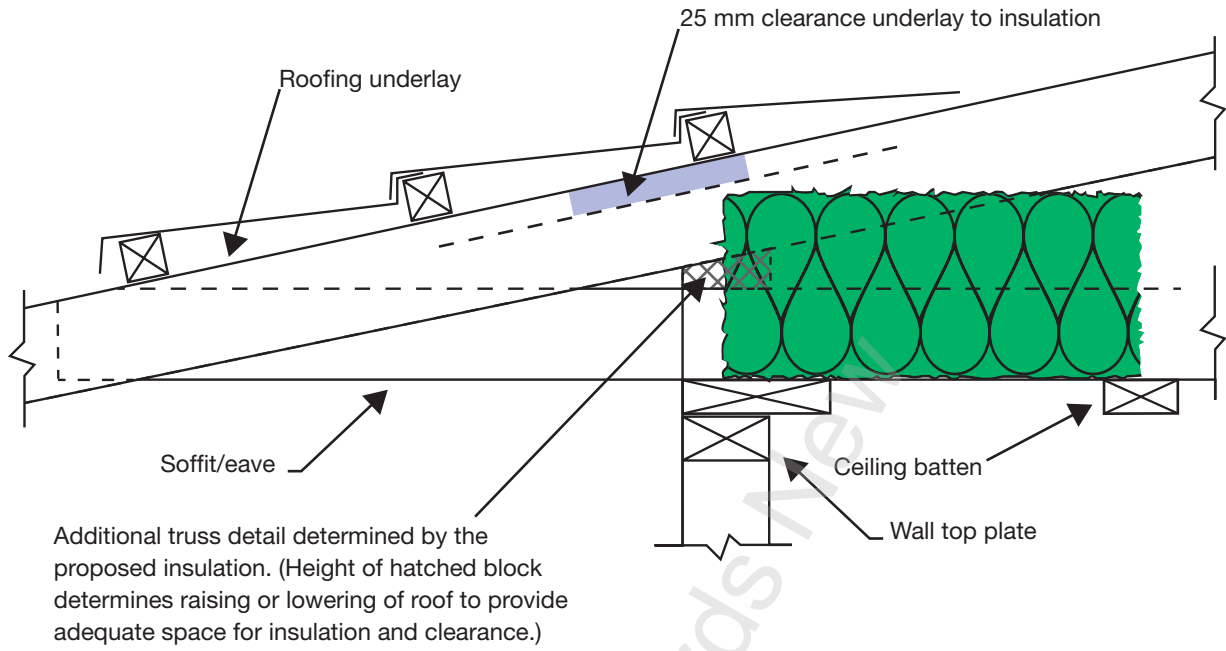


Figure 24 – Low-pitch roof with metal tiles

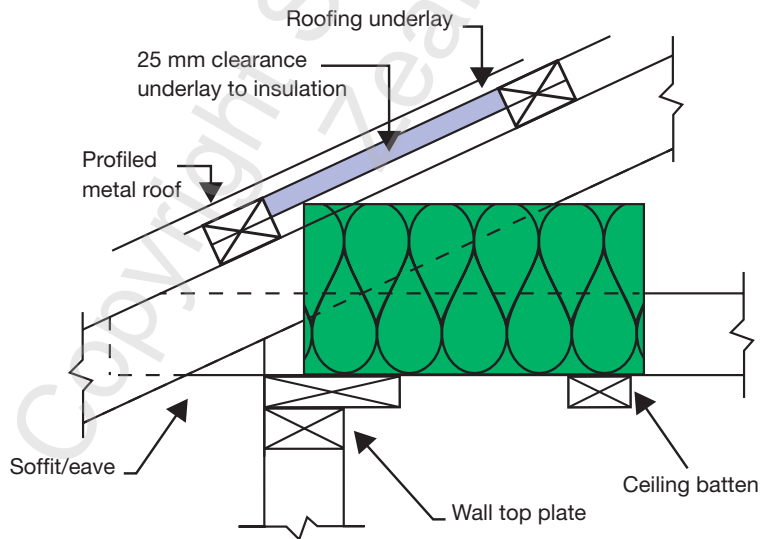


Figure 25 – Profiled metal roof

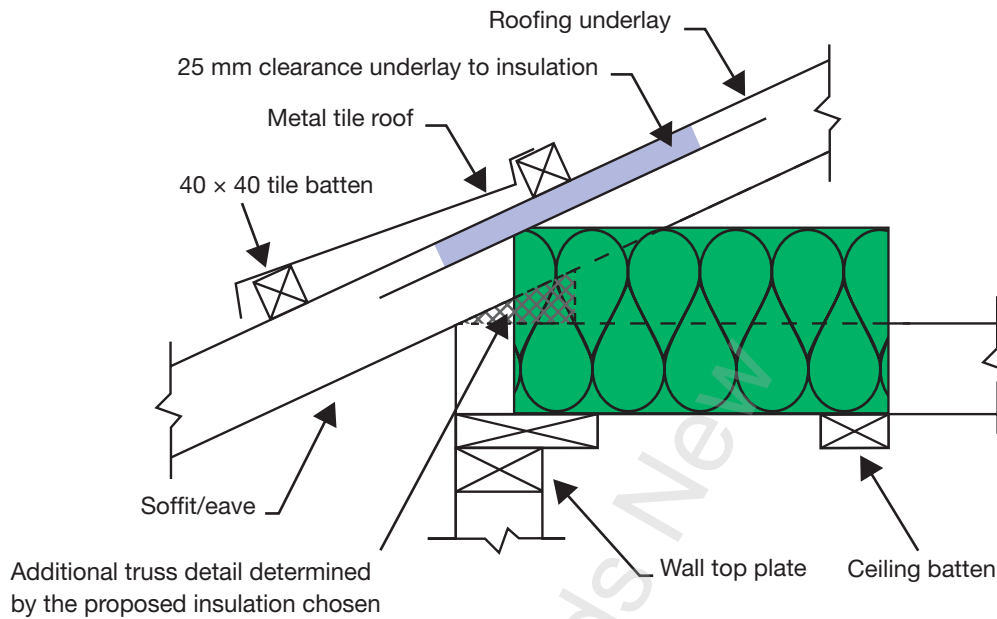


Figure 26 – Metal tile roof

**6.2.11 Installing insulation around ventilation systems in roof spaces**

Keep the insulation at least 50 mm clear of any electrical or heating equipment.

Fit the insulation under flexible ducting provided this can be done without causing damage. Otherwise butt the insulation to the duct from both sides.

If the mechanical or passive ventilation is not ducted to the exterior of the building, clearances are required to ensure that the insulation does not enter or block open fan units or vents through ceilings. See 6.2.12 and 6.2.13 for details.

**6.2.12 Unducted mechanical fan units**

A clearance of 200 mm shall be maintained around any unducted or open fan units. Examples of such units can be bathroom or kitchen extractor fans mounted directly to the ceiling and kitchen rangehoods that protrude into the ceiling space but are not ducted to the exterior.

For new loose-fill insulation this clearance shall be set by placing a guard around the unducted fan unit. The guard shall extend at least 75 mm above the installed insulation layer and be permanently fixed to prevent dislodgement when installing insulation.

For all other insulation materials, clearances shall be set by either:

- (a) Placing a permanently fixed guard around the unducted fan unit; or
- (b) Permanently securing all insulation near the unducted fan unit in position. Acceptable means of permanently securing insulation in position include mechanically fixing or gluing insulation to the ceiling framing or lining, or, for semi-rigid or rigid sheet insulation, firm friction-fitting of all insulation pieces between framing. Clear any existing loose-fill insulation at least 300 mm away from the unducted fan unit and block off with the new, permanently fixed insulation in a way that prevents loose-fill insulation contacting the unducted fan unit.

Block off any gaps between the ceiling insulation and the ceiling lining around the unducted fan unit (see 6.2.9).

Building owners shall be notified that the fan unit is unducted and that the insulation shall be kept clear of the fan unit.

### 6.2.13 Unducted passive vents

Subject to approval from the building owner, passive (non-mechanical) vents that open into the roof space shall be sealed and insulation installed to cover the vents.

Tape plastic sheet over the top of the vent around all edges to form an air-tight seal. Alternatively, the vent shall be covered with a sheet of plastic (insulation bale wrap is acceptable) of at least three times the size of the vent. Plastic shall be positioned to fully cover the vent and to extend equally on all sides beyond the vent.

Where passive vents remain functional, maintain a clearance of 200 mm around the vents to contain the insulation.

#### **C6.2.12 and C6.2.13**

*Installers can recommend to the building owner to:*

- (a) *Duct fans to the exterior of the building and then fully insulate the ceiling;*
- (b) *Seal passive vents or ducts before insulating the ceiling.*

*Passive vents and unducted fans can:*

- (c) *Allow insulation and other particles from the roof space to enter the interior during windy weather;*
- (d) *Allow warm air from inside to escape (making the room hard to heat);*
- (e) *Transfer excessive moisture into the roof space (compromising the performance of the insulation by increasing the amount of roof condensation);*
- (f) *Reduce condensation inside by allowing the internal moisture to escape.*

### 6.2.14 Chimneys and flues

Keep the insulation 75 mm clear around metal chimneys and flues and 50 mm clear of brick chimneys.

### 6.2.15 Luminaires

Follow section 4.

### 6.2.16 Avoiding condensation in roof spaces

To avoid condensation, insulated ceilings shall be lined on the underside of the insulation.

**6.2.17 Insulating skylight shafts**

Skylight shafts through roof spaces shall be insulated using an appropriate insulation product (see section 5). The insulation shall be permanently held in place in a way that ensures full contact of the insulation with the skylight shaft wall lining, without undue compression of the insulation.

NOTE – One way of achieving this is to fix strapping horizontally to the framing at intervals no greater than 300 mm centres.

**6.2.18 Access hatches**

Where the access hatch forms part of the thermal envelope, insulate the access hatch with a separate piece of insulation, ensuring a snug fit with surrounding insulation or ceiling framing when the hatch is closed. Wherever practicable, permanently fix the insulation to the top of the hatch using mechanical fixings or suitable adhesive.

**6.3 Segments and blankets insulation – unlined ceilings**

**6.3.1 Installation**

Guidance for installing segments and blanket insulation products in unlined ceilings is set out in 6.3.

In truss roof design, blanket and segments shall always be installed between trusses, except for the second layer of a double-layer system.

**6.3.2 Segments (installation between ceiling joists or truss chords from underneath)**

The following steps shall be taken when installing insulation segments in unlined ceilings from underneath (see Figure 27).

Step	Action
1.	Follow the manufacturer’s instructions.
2.	Cut the segments in accordance with the manufacturer’s instructions to allow a good friction-fit.
3.	Push the cut segments into the ceiling space between ceiling joists or truss chords, over the ceiling battens. Make sure there are no gaps around the outer edges of the segments and no folds in the segments themselves. Where segments are butted together make sure there are no gaps between them.
4.	Fit insulation snugly around plumbing located within the insulation layer, minimising gaps, tucks, or folds in the insulation while taking care not to damage the plumbing.

Step	Action
5.	<p>Continue fitting the insulation to all accessible ceiling and roof areas that form part of the thermal envelope, except where insulation clearances are required, including:</p> <ul style="list-style-type: none"> <li>(a) Around recessed or surface-mounted luminaires (see 4.2 and 4.3);</li> <li>(b) Around independent controlgear (see 4.4);</li> <li>(c) Around fan/heat/light units (see 4.6);</li> <li>(d) Around built-in appliances or enclosures containing electrical equipment (see 3.2);</li> <li>(e) Around unducted mechanical fan units (see 6.2.12);</li> <li>(f) Around unducted passive vents that remain functional (see 6.2.13);</li> <li>(g) Around chimneys and flues (see 6.2.14);</li> <li>(h) Under concrete header tanks in climate zone 3 and in locations prone to freezing (see 6.2.5).</li> </ul> <p>Areas outside the thermal envelope need not be insulated, including porch areas and garages.</p>
6.	<p>Fit the insulation at least halfway over exterior wall top plates (except where obstructed by other framing members such as ceiling joists) while ensuring minimal overflow into the eaves.</p> <p>Maintain a minimum clear space of 25 mm between the insulation product and either flexible roof underlay or the roofing (if exposed). See 6.2.10 for more detail.</p>
7.	<p>At the end of the installation, check and repair any visible gaps, tucking in, or folds. Check that any required clearances have been left correctly.</p>
8.	<p>Provide a product label and installer information to the building owner or other authorised person in accordance with 2.7.</p>



Figure 27 – Segments installed in a ceiling

**6.3.3 Blanket (installation between ceiling joists or truss chord from above or beneath)**

The following steps shall be taken when installing blanket products between ceiling joists or truss chords.

Step	Action
1.	Follow the manufacturer's instructions.
2.	Level any existing insulation and remove any damp insulation. Refit any displaced existing insulation before installing new insulation.
3.	Use blankets of the correct width.
4.	Pull the blankets into the ceiling space and place them between ceiling joist/truss chords and over the ceiling battens.
5.	Fit the blanket slightly oversize to ensure a good edge friction-fit.
6.	For distances between ceiling joists or truss chords that are non-standard, cut, trim, or tear blanket to suit, and fit perpendicular to the ceiling joists or truss chords.
7.	Make sure there are no gaps around the outer edges of the blankets and no folds or tucking in the blankets. Where blankets are butted together make sure there are no gaps between them.
8.	Fit insulation snugly around plumbing located within the insulation layer, minimising gaps, tucks, or folds in the insulation while taking care not to damage the plumbing.
9.	Continue fitting the insulation to all accessible ceiling and roof areas that form part of the thermal envelope, except where insulation clearances are required, including: <ul style="list-style-type: none"> <li>(a) Around recessed or surface-mounted luminaires (see 4.2 and 4.3);</li> <li>(b) Around independent controlgear (see 4.4);</li> <li>(c) Around fan/heat/light units (see 4.6);</li> <li>(d) Around built-in appliances or enclosures containing electrical equipment (see 3.2);</li> <li>(e) Around unducted mechanical fan units (see 6.2.12);</li> <li>(f) Around unducted passive vents that remain functional (see 6.2.13);</li> <li>(g) Around chimneys and flues (see 6.2.14);</li> <li>(h) Under concrete header tanks in climate zone 3 and in locations prone to freezing (see 6.2.5).</li> </ul> Areas outside the thermal envelope need not be insulated, including porch areas and garages.
10.	Fit the insulation at least halfway over exterior wall top plates (except where obstructed by other framing members such as ceiling joists) while ensuring minimal overflow into the eaves.  Maintain a minimum clear space of 25 mm between the insulation product and either flexible roof underlay or the roofing (if exposed). See 6.2.10 for more detail.
11.	If necessary, apply strapping to support the blanket until the lining is fitted (see Figure 28).
12.	At the end of the installation, check and repair any visible gaps, tucking in, or folds. Check that any required clearances have been left correctly.
13.	Provide a product label and installer information to the building owner or other authorised person in accordance with 2.7.



Figure 28 – Blanket in a ceiling secured with strapping

## 6.4 Segments and blankets insulation – lined ceilings

### 6.4.1 Installation within roof space

Guidance for installing insulation in lined ceilings from within the roof space is set out in 6.4.

### 6.4.2 Segments

When installing segment insulation in ceilings it should be friction-fitted between ceiling joists or truss chords (see Figure 29), except where it is installed as a second layer over existing insulation, which consistently has at least the same height as the top of the ceiling joists or truss chords.

The following steps shall be taken to install insulation segments in lined ceilings.

Step	Action
1.	Follow the manufacturer’s instructions.
2.	Level any existing insulation and remove any damp insulation. Refit any displaced existing insulation before installing new insulation.  Except where clearances are required, fill any remaining gaps that are greater than 50 mm width in the existing insulation with insulation before installing new insulation over the top.
3.	Start installing insulation at the furthest points from the ceiling access hatch.



Step	Action
4.	<p>Cut the segments in accordance with the manufacturer’s instructions to allow a good friction-fit between ceiling joists or truss chords, over the ceiling battens (see Figure 29).</p> <p>Where segments are installed as a second layer over existing insulation, which consistently has at least the same height as the top of the ceiling joists or truss chords, make sure the segments cover both the existing insulation and the ceiling joists or truss chords. Make sure there are no gaps between the layers of insulation.</p> <p>Make sure there are no gaps around the outer edges of the segments and no folds in the segments themselves. Where segments are butted together make sure there are no gaps between them.</p>
5.	<p>Continue fitting the insulation to all accessible ceiling and roof areas that form part of the thermal envelope, except where insulation clearances are required, including:</p> <ul style="list-style-type: none"> <li>(a) Around recessed or surface-mounted luminaires (see 4.2 and 4.3);</li> <li>(b) Around independent controlgear (see 4.4);</li> <li>(c) Around fan/heat/light units (see 4.6);</li> <li>(d) Around built-in appliances or enclosures containing electrical equipment (see 3.2);</li> <li>(e) Around unducted mechanical fan units (see 6.2.12);</li> <li>(f) Around unducted passive vents that remain functional (see 6.2.13);</li> <li>(g) Around chimneys and flues (see 6.2.14);</li> <li>(h) Under concrete header tanks in climate zone 3 and in locations prone to freezing (see 6.2.5).</li> </ul> <p>For retrofitting ceiling insulation, see Table A1 in Appendix A for a summary of clearance requirements.</p> <p>Areas outside the thermal envelope need not be insulated, including porch areas and garages.</p>
6.	<p>Along the perimeter of the ceiling and around other edges of the insulation layer, for example around insulation clearances, block off any open air pockets between the ceiling insulation and the ceiling lining to stop airflow. See 6.2.9 for details.</p> <p>NOTE – Poles may be used to push insulation into difficult to reach corners, but take care that the insulation does not fold or tear.</p>
7.	<p>Fit insulation snugly around plumbing located within the insulation layer, minimising gaps, tucks, or folds in the insulation while taking care not to damage the plumbing.</p>
8.	<p>Fit the insulation at least halfway over exterior wall top plates (except where obstructed by other framing members such as ceiling joists) while ensuring minimal overflow into the eaves.</p> <p>Maintain a minimum clear space of 25 mm between the insulation product and either flexible roof underlay or the roofing (if exposed). See 6.2.10 for more detail.</p>



Step	Action
9.	At the end of the installation the installer shall check and repair any visible gaps, tucking in, or folds. Check that any required clearances have been left correctly.
10.	Fit a segment of insulation to the access hatch (see 6.2.18).
11.	Provide a product label and installer information to the building owner or other authorised person in accordance with 2.7.



Figure 29 – Friction-fitting insulation over joists

#### 6.4.3 Blanket over framing

In lined ceilings blanket insulation can be installed over the joists. When installed in this way it shall be installed perpendicular to the joists. In trussed roofs, blanket should always be installed between truss chords, in that case follow the steps in 6.3.3.

The following steps shall be taken to install blanket over framing.

Step	Action
1.	Follow the manufacturer’s instructions.
2.	Level any existing insulation and remove any damp insulation. Refit any displaced existing insulation before installing new insulation.  Except where clearances are required, fill any remaining gaps that are greater than 50 mm width in the existing insulation with insulation before installing new insulation over the top.
3.	Start installing insulation at the furthest points from the ceiling’s access hatch.  NOTE – Poles may be used to push blanket insulation into difficult to reach corners. Take care that the insulation does not fold or tear.
4.	Install the blanket so as to prevent the ends of the blanket creeping apart.  Where roll lengths are butted together to form longer lengths, position these joins in between joists.  Use a supporting bridge to achieve a stable friction-fit between adjacent blanket insulation rolls by positioning insulation offcuts under the ends of the two blankets to ensure the end connections are at the same height and square to one another.

Step	Action
5.	Cut the blanket to fit to the edges of strongbacks.
6.	<p>Continue fitting the insulation to all accessible ceiling and roof areas that form part of the thermal envelope, except where insulation clearances are required, including:</p> <ul style="list-style-type: none"> <li>(a) Around recessed or surface-mounted luminaires (see 4.2 and 4.3);</li> <li>(b) Around independent controlgear (see 4.4);</li> <li>(c) Around fan/heat/light units (see 4.6);</li> <li>(d) Around built-in appliances or enclosures containing electrical equipment (see 3.2);</li> <li>(e) Around unducted mechanical fan units (see 6.2.12);</li> <li>(f) Around unducted passive vents that remain functional (see 6.2.13);</li> <li>(g) Around chimneys and flues (see 6.2.14);</li> <li>(h) Under concrete header tanks in climate zone 3 and in locations prone to freezing (see 6.2.5).</li> </ul> <p>For retrofitting ceiling insulation, see Table A1 in Appendix A for a summary of clearance requirements.</p> <p>Areas outside the thermal envelope need not be insulated, including porch areas and garages.</p>
7.	Along the perimeter of the ceiling and around other edges of the insulation layer, for example around insulation clearances, block off any open air pockets between the ceiling insulation and the ceiling lining to stop airflow. See 6.2.9 for details.
8.	Fit insulation snugly around plumbing located within the insulation layer, minimising gaps, tucks, or folds in the insulation while taking care not to damage the plumbing.
9.	<p>Fit the insulation at least halfway over exterior wall top plates (except where obstructed by other framing members such as ceiling joists) while ensuring minimal overflow into the eaves.</p> <p>Maintain a minimum clear space of 25 mm between the insulation product and either flexible roof underlay or the roofing (if exposed). See 6.2.10 for more detail.</p>
10.	At the end of the installation check and repair any visible gaps, tucking in, or folds. Check that any required clearances have been left correctly.
11.	Where two layers of blanket are to be installed, fit the second layer perpendicular to the first layer and repeat steps 3 to 10. Make sure there are no gaps between the layers of insulation.
12.	Fit a segment of insulation equivalent to the design R-value to the access hatch (see 6.2.18).
13.	Provide a product label and installer information to the building owner or other authorised person in accordance with 2.7.

## 6.5 Rigid sheet insulation – unlined and lined ceilings

When installing rigid sheet insulation in ceilings it shall be friction-fitted between ceiling joists or truss chords (except for the second layer of a double layer system) in accordance with the following steps.

Step	Action
1.	Follow the manufacturer's instructions.
2.	Level any existing insulation and remove any damp insulation. Refit any displaced existing insulation before installing new insulation.  Except where clearances are required, fill any remaining gaps that are greater than 50 mm width in the existing insulation with insulation before installing new insulation over the top.
3.	Install insulation product between ceiling joists or truss chords, making sure there are no gaps.
4.	Along the perimeter of the ceiling and around other edges of the insulation layer, for example around insulation clearances, block off any open air pockets between the ceiling insulation and the ceiling lining to stop airflow. See 6.2.9 for details.
5.	Fit insulation snugly around plumbing located within the insulation layer, minimising gaps, tucks, or folds in the insulation while taking care not to damage the plumbing.
6.	Continue fitting the insulation to all accessible ceiling and roof areas that form part of the thermal envelope, except where insulation clearances are required, including: <ul style="list-style-type: none"> <li>(a) Around recessed or surface-mounted luminaires (see 4.2 and 4.3);</li> <li>(b) Around independent controlgear (see 4.4);</li> <li>(c) Around fan/heat/light units (see 4.6);</li> <li>(d) Around built-in appliances or enclosures containing electrical equipment (see 3.2);</li> <li>(e) Around unducted mechanical fan units (see 6.2.12);</li> <li>(f) Around unducted passive vents that remain functional (see 6.2.13);</li> <li>(g) Around chimneys and flues (see 6.2.14);</li> <li>(h) Under concrete header tanks in climate zone 3 and in locations prone to freezing (see 6.2.5).</li> </ul> For retrofitting ceiling insulation, see Table A1 in Appendix A for a summary of clearance requirements.  Areas outside the thermal envelope need not be insulated, including porch areas and garages.
7.	Fit the insulation at least halfway over exterior wall top plates (except where obstructed by other framing members such as ceiling joists) while ensuring minimal overflow into the eaves.  Maintain a minimum clear space of 25 mm between the insulation product and either flexible roof underlay or the roofing (if exposed). See 6.2.10 for more detail.



Step	Action
8.	At the end of the installation, check for and repair any visible gaps. Check that any required clearances have been left correctly.
9.	Fit a segment of insulation equivalent to the design R-value to the access hatch (see 6.2.18).
10.	Provide a product label and installer information to the building owner or other authorised person in accordance with 2.7.

## 6.6 Loose-fill insulation – lined ceilings

### 6.6.1 Insulation materials

Loose-fill insulation materials are commonly manufactured off site with the finished product being formed on site using specialised machinery and proprietary systems. The product’s performance relies on the installer and the installation methods to achieve the stated performance. It is therefore essential that the installer is qualified and the installation system is well developed.

Formed-in-place foam materials are not part of the loose-fill classification and excluded from the scope of this standard, but would require many of the same installation system characteristics.

### 6.6.2 Installing loose-fill ceiling insulation

The following steps, in conjunction with the special considerations in section 2 and 6.2, shall be taken to install loose-fill insulation in lined ceilings.

Step	Action
1.	Level any existing insulation to allow new insulation to be installed to a finished level and even appearance. Remove any damp insulation. Refit any displaced existing insulation before commencing work.
2.	Follow the manufacturer’s instructions.
3.	For sloped ceilings, make sure the slope of the ceiling surface does not exceed 30 degrees from horizontal. For steeper slopes use an alternative, suitable insulation product that is not loose-fill.
4.	Install depth markers before commencing installation. Attach the markers to joists or trusses at a minimum of every 30 square meters, facing the access hatch for easy inspection.  NOTE – The markers are necessary to determine the initial R-value of the insulation during installation, as manufacturers assign an R-value to their product based on depth.
5.	Use a blowing machine that has the facility for adjustment of material flow. Make sure the machine is well maintained and has a service history.
6.	Use the installed thickness/coverage chart provided by the insulation manufacturer to ensure the appropriate amount of insulation is being installed. Adjust the machine setting as necessary to ensure consistent manufacturer’s design density, particularly if pumping over longer-than-usual distances or above-usual height, for example above two storeys. The weight of material shall not exceed the design capacity of the ceiling lining.

Step	Action
7.	<p>Install the insulation from the outer edges of the area to be insulated back into the centre and to the access hatch to minimise disturbance of any product already laid.</p> <p>Use rigid pipes as necessary to access areas inaccessible by other means.</p>
8.	<p>Install the insulation at least halfway over exterior wall top plates (except where obstructed by other framing members such as ceiling joists) while ensuring minimal overflow into the eaves. Maintain a minimum clear space of 25 mm between the insulation product and either flexible roof underlay or the roofing (if exposed), see 6.2.10 for more detail.</p> <p>Low-pitched roofs may restrict the thickness of the insulation which can be installed, particularly at the eaves where the distance from the ceiling to roof may be less than the manufacturer's 'minimum thickness'. In these situations it is important to ensure:</p> <ul style="list-style-type: none"> <li>(a) Eave area insulation is fully and properly installed;</li> <li>(b) Excess insulation is blown into the open area;</li> <li>(c) The correct number of bags for the total square metreage are used.</li> </ul>
9.	<p>Continue installing the insulation to all accessible ceiling areas that form part of the thermal envelope, except where insulation clearances are required, including:</p> <ul style="list-style-type: none"> <li>(a) Around recessed or surface-mounted luminaires (see 4.2 and 4.3);</li> <li>(b) Around controlgear (see 4.4);</li> <li>(c) Around fan/heat/light units (see 4.6);</li> <li>(d) Around built-in appliances or enclosures containing electrical equipment (see 3.2);</li> <li>(e) Around unducted mechanical fan units (see 6.2.12);</li> <li>(f) Around unducted passive vents that remain functional (see 6.2.13);</li> <li>(g) Around chimneys and flues (see 6.2.14);</li> <li>(h) Under concrete header tanks in climate zone 3 and in locations prone to freezing (see 6.2.5).</li> </ul> <p>For retrofitting ceiling insulation, see Table A1 in Appendix A for a summary of clearance requirements.</p> <p>Where possible insulate under any plumbing pipes, ducts, electrical cables, bracing timbers (strongbacks), and platforms, except where 6.2.5 requires otherwise.</p> <p>Areas outside the thermal envelope need not be insulated, including porch areas and garages.</p>
10.	<p>Make sure the insulation is of an even depth throughout the ceiling.</p>
11.	<p>Fit a segment of insulation (that is not loose-fill) equivalent to the design R-value to the access hatch (see 6.2.18).</p>
12.	<p>Provide a product label and installer information to the building owner or other authorised person in accordance with 2.7. Make sure the labels are signed by the installer verifying the information is correct.</p>



## NOTES

Copyright Standards New Zealand

## SECTION 7

# UNDERFLOOR – SUSPENDED FRAMED FLOORS

- 7.1 **General**
- 7.2 **Special considerations**
- 7.3 **Blanket underfloor insulation**
- 7.4 **Rigid sheet underfloor insulation**
- 7.5 **Semi-rigid underfloor insulation**

Copyright Standards New Zealand  
Zealand

Copyright Standards New  
Zealand



## 7 UNDERFLOOR – SUSPENDED FRAMED FLOORS

### 7.1 General

Before installing insulation the following checks shall be made by the insulation installer or alternatively the insulation installer shall confirm that these checks have been made.

### 7.2 Special considerations

#### 7.2.1 Inspections before installing insulation in existing suspended floors

Before installing insulation the insulation installer shall make the following checks or shall ensure the following checks have been made.

Step	Action
1.	Check for health and safety hazards on site. Appendix B contains health and safety information. In buildings with existing foil insulation, follow NZECP 55 (see 2.9).
2.	Make sure all materials are dry and cleaned of any contaminants, including mould and asbestos. Make sure any damp, wet or unsanitary existing insulation is removed before insulation is fitted. Follow WorkSafe New Zealand guidelines for identification and removal of asbestos.
3.	Check the entire subfloor area for storm and surface water entering the subfloor space, leaking water and sewerage pipes or any water damage (for example, rot or mould) to building elements.  If in doubt, consult a suitably qualified building surveyor or licensed building practitioner before insulation is installed. Make sure any such deficiencies are remedied before installing underfloor insulation.
4.	If a green/black-coloured mould is found, stop work immediately. Notify the building owner or other authorised person that a testing lab will need to identify if the mould is a toxic variety (stachybotrys).
5.	Remove non-toxic mould by thoroughly cleaning the surfaces with either a proprietary mould remover or a household bleach solution (100 ml of bleach per 1 litre of water). Allow surfaces to dry thoroughly.  The building owner will need to have a specialist contractor remove toxic mould (stachybotrys) before insulation installation continues.
6.	Refer all incidences of rot or borer to the building owner for appropriate remediation before installing insulation.
7.	Identify areas where insulation clearances from plumbing pipes and fittings, luminaires, and enclosures containing electrical equipment are required (detailed clearance requirements are provided in sections 3, 4, and 7).  Inform the building owner or other authorised person of areas that cannot be insulated, including where and why clearances will be left.
8.	Check for any existing ineffective insulation materials that need removing before installing new insulation.  Remove existing foil insulation before installing new insulation. Follow NZECP 55 (see 2.9). Also see Table B5 for tips on safe removal of existing underfloor insulation.



Step	Action
9.	Identify any walls between the subfloor space and habitable areas. These should be insulated with wall insulation product in accordance with section 5.
10.	Measure the clear spacing between floor joists to determine the required width of underfloor insulation to be fitted between the framing. Be aware that joist spacing within the same building can vary greatly.

### 7.2.2 Inspections before installing insulation in new suspended floors

Before installing insulation, the following checks shall be made by the insulation installer or alternatively the insulation installer shall confirm that these checks have been made.

Step	Action
1.	Check for health and safety hazards on site. Appendix B contains health and safety information.
2.	Make sure all materials are dry and cleaned of any contaminants, including mould.
3.	Identify areas where insulation clearances from plumbing pipes and fittings, luminaires, and enclosures containing electrical equipment are required (detailed clearance requirements are provided in sections 3, 4, and 7). Inform the building owner or other authorised person of areas that cannot be insulated, including where and why clearances will be left.
4.	Identify any walls between the subfloor space and habitable areas. These shall be insulated with wall insulation product in accordance with section 5.
5.	Measure the clear spacing between floor joists to determine the required width of underfloor insulation to be fitted between the framing. Be aware that joist spacing within the same building can vary greatly.

### 7.2.3 Choosing an underfloor insulation product

The following steps shall be taken when choosing an underfloor insulation product.

Step	Action
1.	Make sure the insulation product complies with AS/NZS 4859.1. Refer to the product label of the insulation product for a compliance statement. NOTE – Installing foil insulation in residential buildings with existing electrical installations is banned under the Building Act.
2.	Make sure the product is fit for purpose and designed for insulating suspended floors. For unlined suspended floors in subfloors without a fully enclosed perimeter foundation, insulation products designed for open, exposed floors shall be used. Refer to the manufacturer's instructions.
3.	Check that the insulation product has the correct width for the joist spacing of the subfloor space.
4.	For floors over work or habitable areas (for example, a garage or workshop) that will remain unlined (that is, where the insulation will remain exposed to the interior space after completion of all building work), do not use foamed plastic or combustible insulation.
5.	Make sure foamed plastic insulation complies with the flame propagation criteria as specified in AS 1366. Check with the insulation manufacturer.

Step	Action
6.	Make sure the correct size and types of fixings are used as per manufacturer's instructions. For example in coastal zones and areas where high corrosion of external fittings is common (such as volcanic areas), use stainless steel fixings.

**7.2.4 Plumbing in subfloor spaces**

Maintain a clearance of approximately 100 mm around all plumbing pipes where they penetrate through the floor to prevent damage in case of water leaks. This gap will also ensure adequate access for repairs to damaged pipes and fittings. Pipes do not require clearances along their entire length.

**7.2.5 Subfloors without enclosed perimeter foundation**

Where there is no continuous enclosed perimeter foundation, one or more of the following steps shall be taken:

- (a) Choose an insulation product that is designed for installation in open-perimeter floor spaces. Refer to the manufacturer's instructions; or
- (b) Line the underside of the suspended floor with a suitable material once the insulation has been installed; or
- (c) Permanently enclose the perimeter of the subfloor. Ensure sufficient openings for subfloor ventilation are provided in accordance with NZS 3604.

**7.3 Blanket underfloor insulation**

The following steps shall be taken to install blanket insulation under suspended floors.

Step	Action
1.	Make sure all insulation is protected from the weather before, during, and after installation. Make sure fitted insulation is undamaged and dry. Do not install insulation until the building is weathertight and the flooring has been installed. Refit any displaced or dislodged existing insulation before installing new insulation.
2.	Follow the manufacturer's instructions.
3.	Make sure all electrical cables and hazards are identified. Installation should be undertaken with the power off. Appendix B contains health and safety information.
4.	Distribute the unopened bags or rolls of insulation to the areas to be covered. If this is not possible then open and distribute a portion at a time to ensure the insulation remains undamaged.
5.	Make sure the correct product width has been selected to match the joist spacing.
6.	Split or open the bags and pull out the product. Run the product in a continuous length between the floor joists and over the main bearers. Ensure that any designated outer layer of the insulation product is facing downwards. In situations where there are blocks between floor joists do not run insulation over these. Make sure insulation stops and starts each side of any such blocking.

Step	Action
7.	Install insulation so that it touches the underside of the floor, without being compressed. Pull insulation tight between the joists to ensure there is no air gap or air movement between the insulation material and the floor, but not so tight as to affect the material loft or thickness.
8.	Fold down the insulation on each side and staple the insulation into place. Staple through the fold-down to the side of the floor joists (see Figure 30), following the manufacturer's instructions. Do not compress the insulation and do not staple directly to the floor. Insulation should be installed without visible folds and compression lines (other than the stapled edge) as this will affect the installed performance. When joining the end of one roll or piece to the start of another, simply butt-join them together, ensuring no gaps, and secure the join by stapling the insulation in place through the fold-down to the side of the floor joists.
9.	Where joist spacing varies, measure the gap by holding the product up to the joists and cut to size as per the manufacturer's instructions.
10.	Continue fitting the insulation to all accessible underfloor areas that form part of the thermal envelope, except where insulation clearances are required, including: <ul style="list-style-type: none"> <li>(a) Approximately 100 mm around all plumbing pipe penetrations through the floor (see 7.2.4);</li> <li>(b) Around surface-mounted luminaires (see 4.3);</li> <li>(c) Around built-in appliances (see 3.2);</li> <li>(d) Around enclosures containing electrical equipment (see 3.2);</li> <li>(e) Around chimneys and flues (see 6.2.14).</li> </ul> For retrofitting underfloor insulation, see Table A2 in Appendix A for a summary of clearance requirements. Areas outside the thermal envelope need not be insulated, including under porch areas and garages.
11.	Install the insulation to the outer edge of the bottom plate of the exterior walls. Where the bottom plate is below the floor level, abut the insulation to it. Do not block the drained or ventilated cavity of exterior walls (for example of brick veneer walls) as this will minimise air circulation and result in excessive moisture in the walls.
12.	At the end of the installation, check and repair any visible gaps, tucking in, or folds. The insulation shall be in full contact with the underside of the floor to ensure no air movement.
13.	On completion, remove all plastic bags and leftover product from the underfloor space. Check that no cables have been damaged.
14.	Provide a product label and installer information to the building owner or other authorised person in accordance with 2.7.



Figure 30 – Installed underfloor blanket

#### 7.4 Rigid sheet underfloor insulation

The following steps shall be taken to install rigid floor insulation under suspended floors (see Figure 31).

Step	Action
1.	Make sure all insulation is protected from the weather before, during, and after installation. Make sure fitted insulation is undamaged and dry. Refit any displaced or dislodged existing insulation before installing new insulation.
2.	Make sure all electrical cables and hazards are identified. Installation should be undertaken with the power off. Appendix B contains health and safety information.
3.	Follow the manufacturer’s instructions. Cut the insulation product to the required width to achieve a snug fit between the floor joists and against the underside of flooring.  NOTE – With some products it can be easier to position one side of the rigid sheet in the corner between the floor and the floor joist and then push up the other side while squeezing the concertina edge. That will ensure a very good friction-fit of the rigid sheet.
4.	Follow the manufacturer’s instructions on fixings required to hold the insulation in place.  When installing rigid sheet insulation under suspended floors without an enclosed perimeter foundation, use fixings to support panels positioned as specified by the manufacturer.

Step	Action
5.	<p>Continue fitting the insulation to all accessible underfloor areas that form part of the thermal envelope, except where insulation clearances are required, including:</p> <ul style="list-style-type: none"> <li>(a) Approximately 100 mm around all plumbing pipe penetrations through the floor (see 7.2.4);</li> <li>(b) Around surface-mounted luminaires (see 4.3);</li> <li>(c) Around built-in appliances (see 3.2);</li> <li>(d) Around enclosures containing electrical equipment (see 3.2);</li> <li>(e) Around chimneys and flues (see 6.2.14).</li> </ul> <p>For retrofitting underfloor insulation, see Table A2 in Appendix A for a summary of clearance requirements.</p> <p>If using polystyrene insulation products, avoid contact between electrical cables and these products. See 3.5 for details.</p> <p>Areas outside the thermal envelope need not be insulated, including under porch areas and garages.</p>
6.	<p>Install the insulation to the outer edge of the bottom plate of the exterior walls. Where the bottom plate is below the floor level about the insulation to it.</p> <p>Do not block the drained or ventilated cavity of exterior walls (for example of brick veneer walls) as this will reduce air circulation and result in excessive moisture in the walls.</p>
7.	<p>At the end of the installation check and repair any visible gaps, and use offcuts of insulation or foam to fill small gaps except around plumbing.</p> <p>The insulation shall be in full contact with the underside of the floor to ensure no air movement.</p>
8.	<p>Provide a product label and installer information to the building owner or other authorised person in accordance with 2.7.</p>

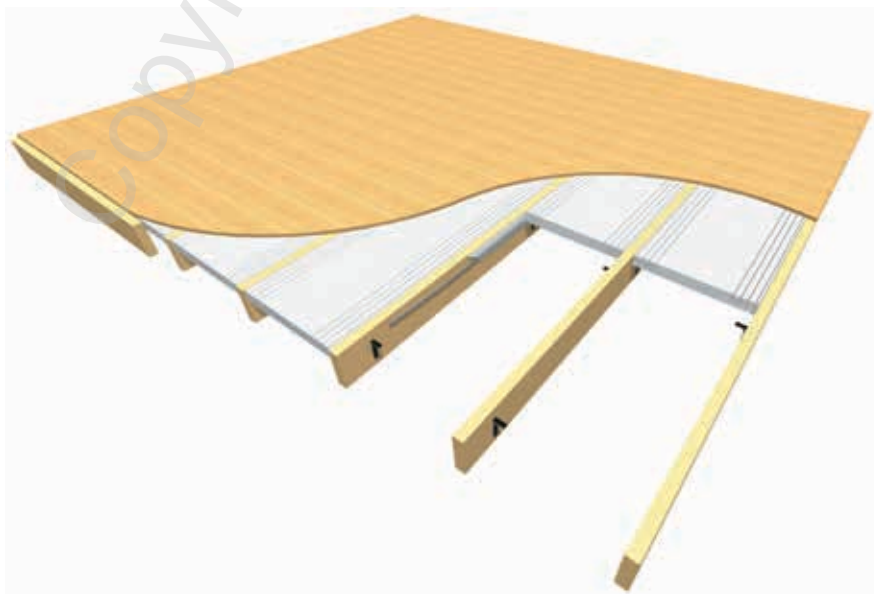


Figure 31 – Installation of underfloor rigid sheet floor insulation

## 7.5 Semi-rigid underfloor insulation

### 7.5.1 Designed for friction fit

Semi-rigid insulation is manufactured and designed for friction-fitting between the joists.

### 7.5.2 Semi-rigid friction-fitted without fixings

For semi-rigid insulation that is installed by friction-fitting the insulation between the floor joists, with or without a specified fold down, the following steps shall be taken.

Step	Action
1.	Make sure all insulation is protected from the weather before, during, and after installation. Make sure fitted insulation is undamaged and dry. Do not install insulation until the building is weathertight and the flooring has been installed. Refit any displaced or dislodged existing insulation before installing new insulation.
2.	Follow the manufacturer's instructions.
3.	Always check the manufacturer's specification for the minimum or maximum joist spacing per sheet. This ensures that the friction-fit is adequate and the sheet does not fall out of the space between the joists. Insulation widths and sheet depths can be found on the product label.
4.	Ensure all electrical cables and hazards are identified. Installation should be undertaken with the power off. Appendix B contains health and safety information.
5.	Hold the long edge of the sheet against the internal corner formed by the joist and the floor junction.
6.	Press the body of the sheet hard up against the underside of the floor, leaving no gap in between (see Figure 32).
7.	Where the manufacturer's instructions require a fold down, fold the trailing edge to make a sharp crease ensuring that the friction-fit is tight and the sheet is secure. Check the depth of the folding edge is correct as specified by the manufacturer (generally 25 – 75 mm).
8.	Where insulation pieces are butted together there shall be no gaps between them.
9.	Where a single joist becomes a double joist and reduces the clear space available for the insulation, make a right-angle cut and fit the semi-rigid insulation so that it fits snugly.
10.	Install the insulation to the outer edge of the bottom plate of the exterior walls. Where the bottom plate is below the floor level about the insulation to it. Do not block the drained or ventilated cavity of exterior walls (for example of brick veneer walls) as this will reduce air circulation and result in excessive moisture in the walls.

Step	Action
11.	<p>Continue fitting the insulation to all accessible underfloor areas that form part of the thermal envelope, except where insulation clearances are required, including:</p> <ul style="list-style-type: none"> <li>(a) Approximately 100 mm around all plumbing pipe penetrations through the floor (see 7.2.4);</li> <li>(b) Around surface-mounted luminaires (see 4.3);</li> <li>(c) Around built-in appliances (see 3.2);</li> <li>(d) Around enclosures containing electrical equipment (see 3.2);</li> <li>(e) Around chimneys and flues (see 6.2.14).</li> </ul> <p>For retrofitting underfloor insulation, see Table A2 in Appendix A for a summary of clearance requirements.</p> <p>Areas outside the thermal envelope need not be insulated, including under porch areas and garages.</p>
12.	<p>At the end of the installation check and repair any visible gaps. The insulation shall be in full contact with the underside of the floor to ensure no air movement.</p>
13.	<p>Provide a product label and installer information to the building owner or other authorised person in accordance with 2.7.</p>



Figure 32 – Fitting semi-rigid sheets



### 7.5.3 Semi-rigid insulation friction-fitted with fixings

For semi-rigid insulation that is installed between the floor joists, with a compression fit and mechanical fixings, the following steps shall be taken.

Step	Action
1.	Make sure all insulation is protected from the weather before, during, and after installation. Make sure fitted insulation is undamaged and dry. Do not start installing insulation until the building is closed in and weathertight and the flooring has been installed. Refit any displaced or dislodged existing insulation before installing new insulation.
2.	Follow the manufacturer's instructions.
3.	Always check the manufacturer's specification for the minimum or maximum joist spacing per sheet. This ensures that the friction-fit is adequate. Insulation widths and sheet depths can be found on the product label.
4.	Make sure all electrical cables and hazards are identified. Installation should be undertaken with the power off. Appendix B contains health and safety information.
5.	Start installation at the point furthest from the access point and work towards it.
6.	Hold the long edge of the sheet against the internal corner formed by the joist and the floor junction.
7.	Press the body of the sheet hard up against the underside of the floor, leaving no gap between the insulation material and underside of the flooring.
8.	Fit the ends of each sheet snugly with no gaps between sheets.
9.	Where a single joist becomes a double joist and reduces the clear space available for the insulation, make a right-angle cut and fit the semi-rigid insulation so that it fits snugly.
10.	Install the insulation to the outer edge of the bottom plate of the exterior walls. Where the bottom plate is below the floor level abut the insulation to it.  Do not block the drained or ventilated cavity of exterior walls (for example of brick veneer walls) as this will reduce air circulation and result in excessive moisture in the walls.
11.	Secure the installation by fixing the insulation with strapping or wires across the width of the insulation. A minimum of three straps or wires should be used per segment.



Step	Action
12.	<p>Continue fitting the insulation to all accessible underfloor areas that form part of the thermal envelope, except where insulation clearances are required, including:</p> <ul style="list-style-type: none"> <li>(a) Approximately 100 mm around all plumbing pipe penetrations through the floor (see 7.2.4);</li> <li>(b) Around surface-mounted luminaires (see 4.3);</li> <li>(c) Around built-in appliances (see 3.2);</li> <li>(d) Around enclosures containing electrical equipment (see 3.2);</li> <li>(e) Around chimneys and flues (see 6.2.14).</li> </ul> <p>For retrofitting underfloor insulation, see Table A2 in Appendix A for a summary of clearance requirements.</p> <p>Areas outside the thermal envelope need not be insulated, including under porch areas and garages.</p>
13.	<p>At the end of the installation check and repair any visible gaps. The insulation shall be in full contact with the underside of the floor to ensure no air movement.</p>
14.	<p>Provide a product label and installer information to the building owner or other authorised person in accordance with 2.7.</p>

## SECTION 8

# ON-GROUND VAPOUR BARRIERS

- 8.1 Special considerations
- 8.2 Installing an on-ground vapour barrier

Copyright Standards New Zealand

Copyright Standards New  
Zealand

## 8 ON-GROUND VAPOUR BARRIERS

### 8.1 Special considerations

#### 8.1.1 General

Section 8 provides guidance for installing on-ground vapour barriers under suspended floors and shall be read in conjunction with sections 1 and 2.

On-ground vapour barriers are installed on the ground under suspended timber floors where there is an enclosed perimeter foundation to prevent ground moisture from evaporating into the subfloor space.

On-ground vapour barriers shall:

- (a) Be a polythene film;
- (b) Have a vapour flow resistance of no less than 50 MN s/g and a thickness of no less than 0.25 mm, for example 250 micron polythene.

#### **C8.1.1**

*The need for vapour barriers can arise from a variety of situations, for example:*

- (a) *Subfloor ventilation is inadequate;*
- (b) *Condensation is appearing in the roof space; or*
- (c) *The ground under the building is damp.*

*Roof space condensation (particularly during winter) can be a significant problem in older buildings and is most often caused by the migration of moist air from the subfloor space to the roof space by the framing and drainage cavities. Buildings most commonly affected are those with masonry veneer cavities and suspended timber floors. The most effective remedy for this problem is to install a vapour barrier to the subfloor area to limit moisture emission from the subfloor space.*

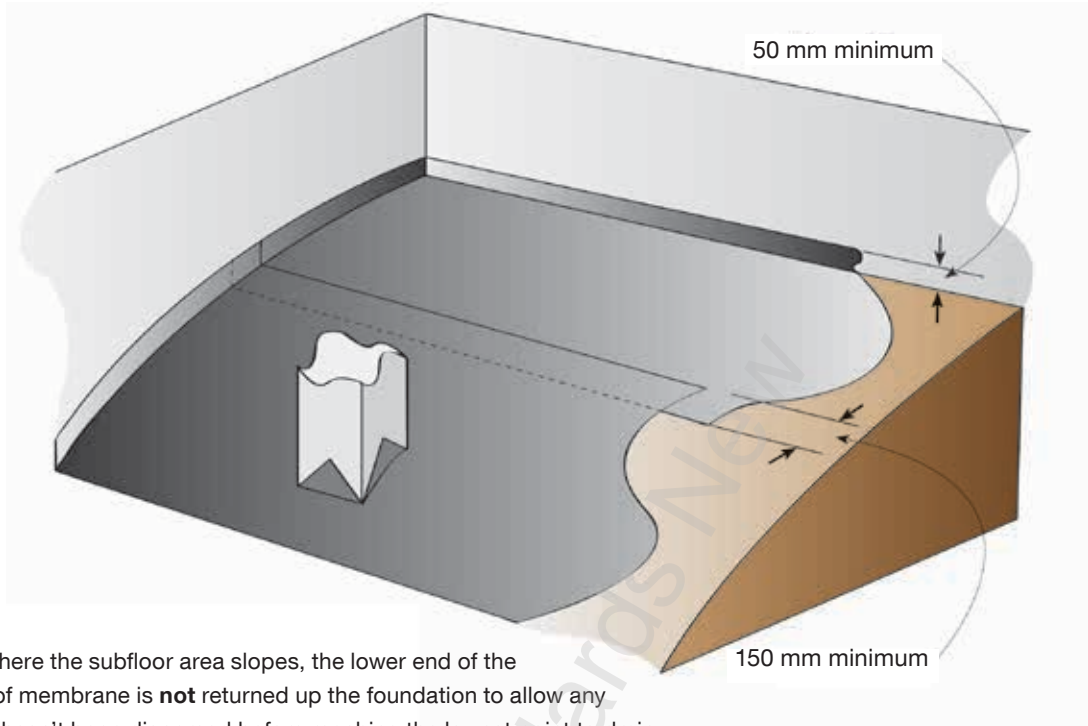
#### 8.1.2 Tongue and groove flooring

Installing an on-ground vapour barrier to properties with tongue-and-groove type timber flooring creates a risk of gaps opening up between boards. This is most commonly found when timber flooring is damp and swollen. After the on-ground vapour barrier is installed the timber can dry out and shrink. This can cause flooring to creak under foot, or develop visible gaps between boards. Building owners should be made aware of this risk before installing an on-ground vapour barrier.

## 8.2 Installing an on-ground vapour barrier

The following steps shall be taken to install an on-ground vapour barrier under suspended floors.

Step	Action
1.	Check the entire subfloor area for storm and surface water entering the subfloor space or leaking water and sewerage pipes. If in doubt, consult a suitably qualified building surveyor or licensed building practitioner before the on-ground vapour barrier is installed. Make sure any such deficiencies are remedied before installing an on-ground vapour barrier.
2.	Prepare the ground to be covered by the vapour barrier by removing any materials that are likely to puncture the polythene.
3.	Roll out a sheet of polythene the length of the house and long enough to be lapped up the foundation walls by a minimum of 50 mm.
4.	Fold the polythene up the inside edge of the foundation walls by a minimum of 50 mm (see Figure 33). On sloping sites leave the lower-most edge of the polythene at least 50 mm short of the foundation wall to allow any moisture that may get on top of the polythene to drain away.
5.	Cut the polythene from the edge of each run to the piles to allow the sheet to be positioned with the slit around the pile.
6.	Make small cuts in the polythene around the piles to allow the sheet to be folded up by a minimum of 50 mm and taped to the piles (see Figure 34). NOTE – Taping around piles is required for durability but not for moisture seal.
7.	Tape all joins and cuts made to allow the piles to protrude through the polythene with the tape covering each side of the join by a minimum of 50 mm.
8.	Overlap joins between polythene sheet runs by a minimum of 150 mm.
9.	Pin or weight down the polythene sheets along the overlaps and edges at intervals of no more than 1 m to secure the sheets in place.
10.	Repeat the process until the entire accessible subfloor area has been covered.



NOTE – Where the subfloor area slopes, the lower end of the damp proof membrane is **not** returned up the foundation to allow any water that hasn't been dispersed before reaching the lowest point to drain.

Figure 33 – On-ground vapour barrier folded up along foundation walls and overlapped along joins



Figure 34 – On-ground vapour barrier folded up and taped around a pile

## NOTES

Copyright Standards New  
Zealand



## SECTION 9

# PIPE INSULATION AND CYLINDER WRAPS

- 9.1 General
- 9.2 Pipe insulation
- 9.3 Hot water cylinder wraps

Copyright Standards New Zealand

Copyright Standards New  
Zealand

## 9 PIPE INSULATION AND CYLINDER WRAPS

### 9.1 General

This section covers insulating electric storage water heaters and the insulation of pipes. Pipe insulation near electric water heaters shall be installed before a cylinder wrap is fitted.

### 9.2 Pipe insulation

#### 9.2.1 Requirements

Pipe insulation is designed to insulate water pipes. Pipe insulation is required in the following circumstances:

- (a) In climate zone 3 (see Appendix D) and locations prone to freezing, along the entire length of all water pipes protruding above ceiling insulation in ceiling spaces (see 6.2.4);
- (b) In new homes, NZS 4305 requires insulation of the vent pipe of hot water cylinders to 300 mm above the standing water level and the first 2 m of the hot water distribution pipe;
- (c) In existing homes, the first 2 m of all hot water distribution pipes coming out from the top of hot water cylinders shall be insulated where possible.

Pipe insulation near hot water cylinders shall be installed before installation of any cylinder wrap.

#### 9.2.2 Hessian-backed wool

The following steps shall be taken to install hessian-backed wool pipe insulation around water pipes.

Step	Action
1.	Identify the water pipes to be insulated. For pipe insulation near hot water cylinders, identify the hot water distribution pipe that comes out from the top of the cylinder.
2.	Secure the insulation (with hessian outermost) using tape or a cable tie around the hot water supply pipe. For pipe insulation near hot water cylinders start where it comes out from the cylinder. NOTE – This prevents the insulation from slipping as it is wound around the pipe.
3.	Wind the insulation firmly up the pipe with a 50% overlap ensuring the pipe is fully covered.
4.	Close off the end of the insulation with tape or a cable tie.
5.	Secure cable ties or tape firmly around the insulation at 200 mm intervals.

### 9.2.3 Pre-formed pipe insulation

The following steps shall be taken to install pre-formed pipe insulation around water pipes.

Step	Action
1.	Identify the water pipes to be insulated. For pipe insulation near hot water cylinders identify the hot water distribution pipe that comes out from the top of the cylinder.
2.	Measure the pipe diameter. Ensure the inner diameter of the pre-formed pipe insulation matches the pipe diameter.
3.	Cut a length of insulation to suit the pipe work.
4.	Slit the insulation lengthwise if required.
5.	Fit the insulation around the water pipe.
6.	At 90° pipe bends butt two lengths of pipe insulation together, with the ends of both pieces cut at 45° angles to form a right-angle join.
7.	Pull the slit closed to fully enclose the pipe, and tape/glue (as per the manufacturer's instructions) lengthwise, taking care not to compress the insulation.
8.	Apply additional tape around the insulation at 120 mm intervals ensuring there are no gaps, or undue compression in the insulation.  NOTE – Additional taping/glue on pipe bends will ensure the integrity of the insulation.

### 9.3 Hot water cylinder wraps

A hot water cylinder wrap is used to insulate an electric hot water cylinder (electric storage water heater), to reduce the standing heat losses from the cylinder (see Figure 35 for an illustration of a completed wrap).

Hot water cylinder wraps shall not be installed on gas storage water heaters.

Hot water cylinder wraps shall be installed as follows.

Step	Action
1.	Ensure that the cylinder is electric. Follow all of the wrap manufacturer's instructions.
2.	Inspect the cylinder and ensure that there are no leaks. Check that visible wiring is in good condition. Ensure that the element/thermostat cover is in place. If a problem is found report it to the owner or other authorised person and discontinue installation.
3.	Turn off the power to the cylinder either at the fuse box or at the isolating switch.
4.	Take care not to damage pipes or electrical wires.
5.	Remove any earthquake strapping and retain pieces.
6.	Measure the height, radius, and circumference of the cylinder.  NOTE – A string can be useful for measuring the circumference.
7.	Remove the cylinder wrap from the bag and lay it out with the exterior facing upwards and mark the dimensions, allowing for overlaps as per the manufacturer's instructions.
8.	Cut to size with a knife.

Step	Action
9.	Find the side with the larger gap between the cylinder and the cupboard to insert the wrap, so the wrap is less likely to jam. A cord can be tied to a bottom corner of the wrap to assist with pulling the wrap around the cylinder.
10.	Pull the join together and partially tape or tag the join. Cut around the element/thermostat cover, taking care not to damage the electric cable.
11.	Gather the top of the wrap tightly around the pipe over the pipe lagging ensuring there are no air gaps and tie tightly with the tie provided. If a circular cylinder wrap lid is provided or required, install it at this stage.
12.	Seal the join down the wrap using the fastening products provided, ensuring a snug fit and repairing any minor tears from installing.
13.	Cut and fit a separate piece of wrap and place over the element/thermostat cover. Use self-adhesive tape to secure.
14.	Reinstall any earthquake strapping previously removed.  NOTE – The compliance documents for NZBC Clause G12 require seismic restraint straps to be fitted to all hot water cylinders. A minimum of two straps is required for cylinders up to 200 litres, and three straps for cylinders greater than 200 litres. The installer should inform the building owner about any deficiencies.
15.	Attach a label or product certificate containing the following information to the wrap so that it is visible for future inspections:  (a) Product name; (b) Name and address of manufacturer; (c) Safety instructions; (d) Nominal net weight of contents (kg); (e) Nominal stabilised thickness; and (f) R-value.
16.	Inspect the job to ensure that the cylinder is fully enclosed and that the air gap around the top and sides of the cylinder is properly sealed.
17.	Turn the power to the cylinder back on.



Figure 35 – Insulated hot water cylinder

## NOTES

Copyright Standards New  
Zealand

## SECTION 10

# CONCRETE SLAB-ON-GROUND INSULATION

- 10.1 Special considerations
- 10.2 Under-slab insulation
- 10.3 Slab perimeter insulation

Copyright Standards New Zealand

Copyright Standards New  
Zealand



## 10 CONCRETE SLAB-ON-GROUND INSULATION

### 10.1 Special considerations

Concrete floor slabs are insulated by placing rigid foam on the prepared ground with the concrete slab formed on top (see Figure 36). Polystyrene is available in various densities and sheet thicknesses. Choosing the correct product will depend on a variety of factors including design of the building, climate zone and the desired insulation value. Where insulation is required under footings or where higher loads are probable, a higher density expanded polystyrene (EPS) or extruded polystyrene (XPS) should be used. A combination of both under-slab insulation and perimeter-edge insulation will provide the highest benefit. Perimeter-edge insulation can either be included during the construction of the floor slab or retrofitted to existing slabs. Some proprietary systems for insulating concrete slabs differ from the generic method described in 10.3.

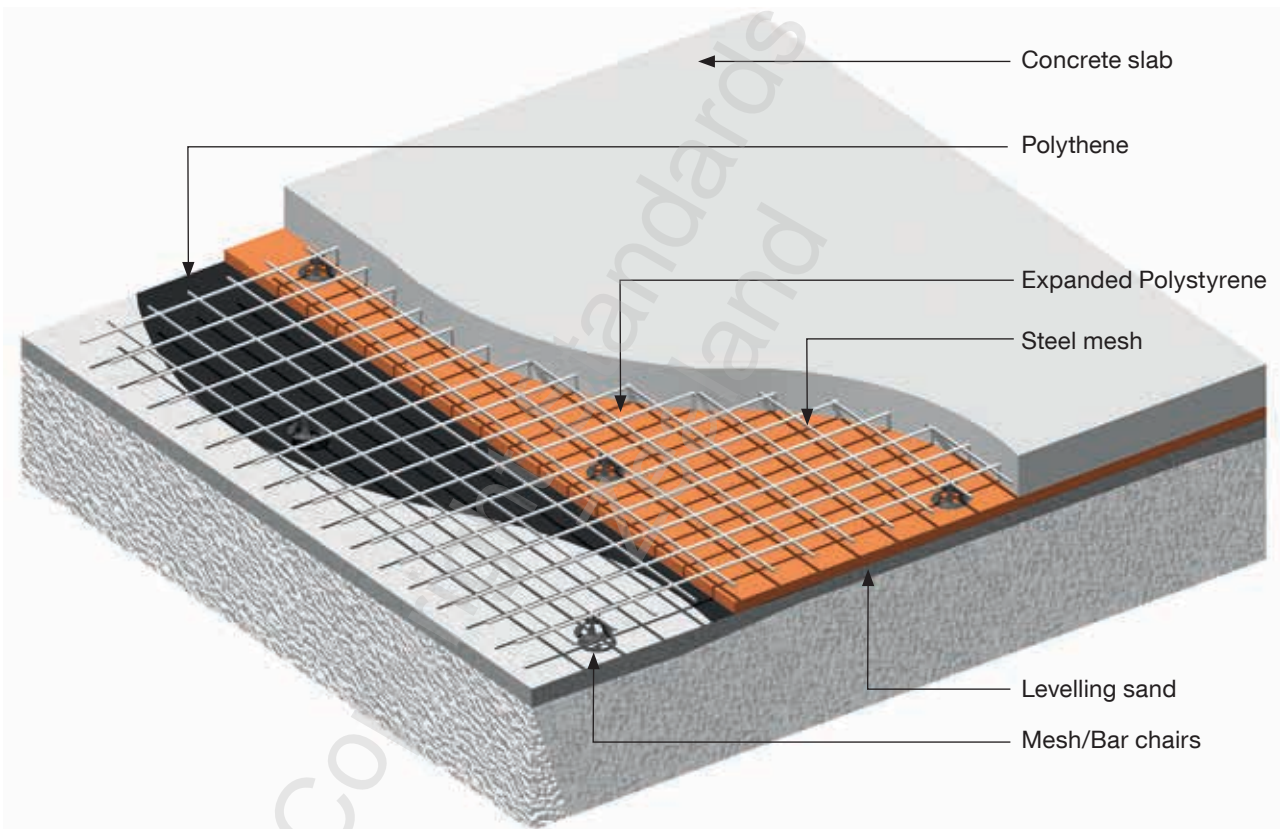


Figure 36 – Under-slab insulation

## 10.2 Under-slab insulation

Expanded polystyrene is a common product to use in domestic concrete floors and will support the weight of people during construction, for example 50 mm thick grade 'S' (typically 16 kg/m<sup>3</sup>). In colder environments or where higher loads are probable a different thickness or density may be required.

NOTE – When insulating under areas of high load or where the product thickness exceeds 100 mm it is recommended that an engineer or the product manufacturer is consulted during the design phase. This will ensure the engineering requirements of the floor are met.

Under-slab insulation shall be installed on prepared ground before forming the concrete slab as follows:

Step	Action
1.	Store and protect foam panels from water and UV exposure before installation following the manufacturer's instructions.
2.	Use granular base fill and sand binding (if required) to prepare the ground in accordance with NZS 3604.
3.	Lay a damp-proof membrane (DPM) on top of the base fill. The DPM shall meet vapour resistance specified in NZS 3604 to prevent both the insulation and slab from absorbing groundwater.
4.	Lay the rigid sheet insulation on top of the DPM. Specific engineering design is required if insulation is installed under areas where slab thickening is needed to support structural internal walls.
5.	Lay out mesh/bar chairs to support the reinforcing steel.
6.	Install the reinforcing steel.

### 10.3 Slab perimeter insulation

Rigid sheet insulation, usually extruded polystyrene (XPS), is the most common product to insulate a slab perimeter (see Figure 37). Rigid sheet insulation with a thermal resistance of  $R 1.0 \text{ m}^2 \cdot \text{C}/\text{W}$  provides the optimum level of perimeter insulation. Extruded polystyrene is less affected by moisture and is more suited for this application.

Step	Action
1.	<p>The insulation should be protected from both water and impact damage after construction.</p> <p>NOTE – Materials that may be suitable for protecting perimeter insulation from impact damage include:</p> <ul style="list-style-type: none"> <li>(a) Magnesium oxide board;</li> <li>(b) UV stabilised plastic sheet materials;</li> <li>(c) Glass fibre reinforced plastic;</li> <li>(d) Outdoor-grade fibre cement sheet;</li> <li>(e) Exterior plaster cladding system applied.</li> </ul>
2.	<p>The areas of perimeter insulation that are buried in the ground should be specifically protected from water absorption. This will generally require some form of encapsulation. Even for the areas above ground it may not be sufficient to simply protect the foam from impact damage – installers should carefully consider both the type and quality of the rigid foam material that is used.</p> <p>NOTE – Possible encapsulation methods for the perimeter insulation include:</p> <ul style="list-style-type: none"> <li>(a) Glass fibre reinforced plastic;</li> <li>(b) PVC;</li> <li>(c) Exterior plaster cladding system applied.</li> </ul>
3.	<p>Insulating the area of the slab perimeter that is above ground is most critical to reducing heat loss. Increasing the depth of the perimeter insulation down to the bottom of the wall footing or below is almost as effective as increasing the thickness. As a rule of thumb, the key factor is the total volume of insulation. For example, 20 mm thick by 600 mm high perimeter insulation has a similar effect as 40 mm thick by 300 mm high perimeter insulation.</p>
4.	<p>Make sure the top edge of the perimeter insulation is tapered and a suitable flashing used to interface with the bottom edge of the wall cladding. It is important to minimise any uninsulated area below the bottom edge of the wall cladding.</p>

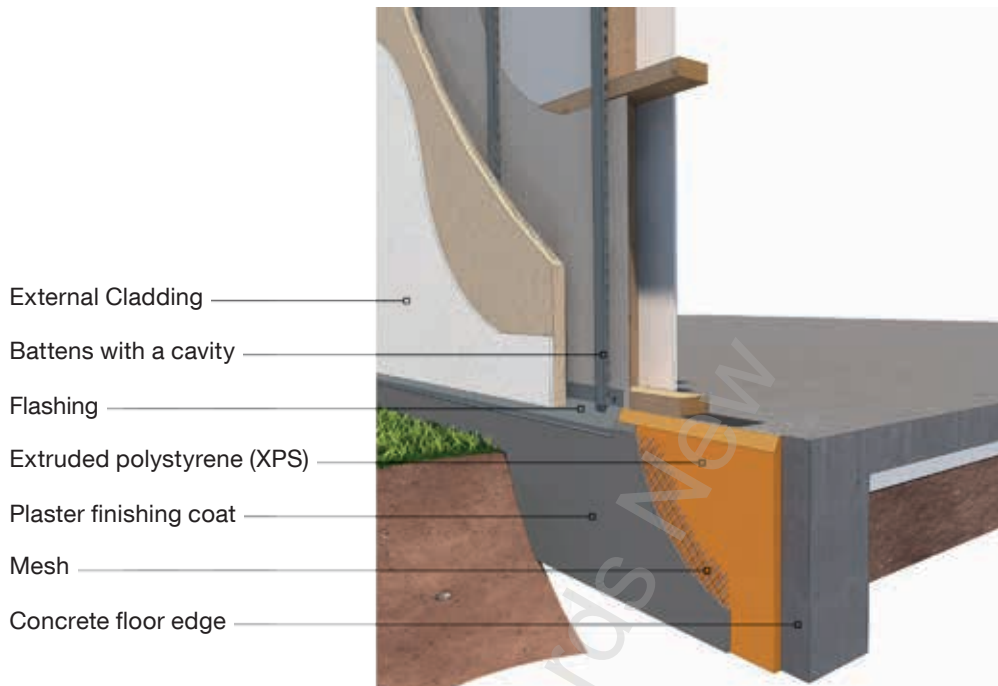


Figure 37 – Slab perimeter insulation

## APPENDIX

- A Clearances (Normative)**
- B Health and safety (Informative)**
- C Warning sign (Informative)**
- D Climate zones (Informative)**

Copyright Standards New Zealand

Copyright Standards New  
Zealand

## APPENDIX A – CLEARANCES

(Normative)

Where the appliance manufacturer’s instructions are not known, use the clearances in Table A1. Do not exceed these minimum clearances by more than 50 mm wherever practicable.

**Table A1 – Clearances in the ceiling**



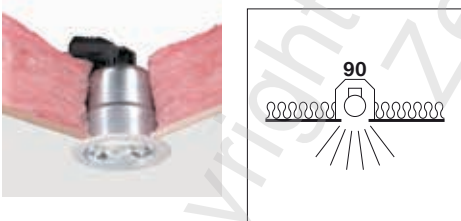



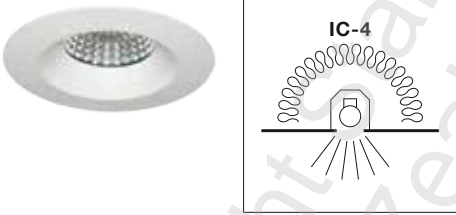


Area	Views: external, from within ceiling, and/or label	Minimum insulation clearance	Comments
Unmarked recessed luminaires		100 mm	See 4.2.2 for instructions. The clearance applies to both new and existing insulation. The insulation is to be secured in position, otherwise a permanently fixed guard or recessed luminaire barrier is required. Do not cover the luminaire.
CA 80 recessed luminaire		Abut, do NOT cover	See 4.2.2 for instructions. New insulation shall be compatible – check the insulation manufacturer’s instructions. Clear existing loose-fill insulation 300 mm away. Do not cover the luminaire.
CA 90 recessed luminaire		Abut, do NOT cover	See 4.2.2 for instructions. New insulation shall be compatible – check the insulation manufacturer’s instructions. Clear existing loose-fill insulation 300 mm away. Do not cover the luminaire.
CA 135 recessed luminaire		Abut, do NOT cover	See 4.2.2 for instructions. New insulation shall be compatible with CA 135 – check the insulation manufacturer’s instructions. Clear existing loose-fill insulation 300 mm away. Do not cover the luminaire.

Table A1 – Clearances in the ceiling (continued)



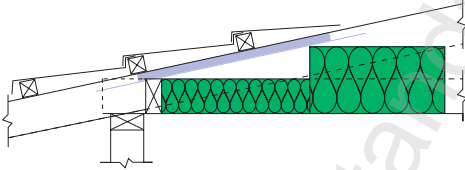
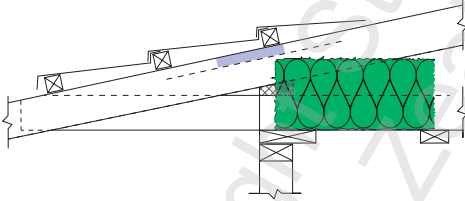
Area	Views: external, from within ceiling, and/or label	Minimum insulation clearance	Comments
IC rated recessed luminaire		Abut and cover	See 4.2.2 for instructions. New insulation shall be compatible – check the insulation manufacturer’s instructions. Clear existing loose-fill insulation 300 mm away.
IC-F rated recessed luminaire		Abut and cover	See 4.2.2 for instructions. New insulation shall be compatible – check the insulation manufacturer’s instructions. Clear existing loose-fill insulation 300 mm away.
IC-4 rated recessed luminaire		Abut and cover	See 4.2.2 for instructions. New insulation shall be compatible – check the insulation manufacturer’s instructions. Clear existing loose-fill insulation 300 mm away.
Independent controlgear (for example auxiliary units, transformers, ballasts, and drivers)		Place on top of insulation or 50 mm clearance. Do NOT cover	See 4.4 for instructions. Place the controlgear on top of insulation where safe and practicable. It shall not sink into the insulation to the extent of the insulation abutting to the sides of the controlgear. Otherwise leave 50 mm clearance.
Surface-mounted luminaire		200 mm	See 4.3 for instructions. The clearance applies in all directions to the nearest part of the luminaire or lamp. Insulation is to be secured in position, otherwise a permanently fixed guard is required.



Area	Views: external, from within ceiling, and/or label	Minimum insulation clearance	Comments
3-in-1 fan/heat/light units		100 mm	See 4.6 for instructions. The clearance applies to both new and existing insulation. Insulation shall be secured in position, otherwise a permanently fixed guard is required.
Ducted fans, rangehoods, or extractors		50 mm	See 3.2 and 6.2.11 for instructions. These shall be fully ducted to the exterior. The clearance applies to both new and existing insulation. Clearance is only required to the actual fan unit and other electrical enclosures. Elsewhere the insulation may be abutted against the outside wall of the duct.
Unducted fans		200 mm	See 6.2.12 for instructions. Unducted fans shall have a 200 mm clearance to prevent debris falling into the motor. The clearance applies to both new and existing insulation.
Unducted rangehoods		200 mm	See 6.2.12 for instructions. Unducted rangehoods shall have a 200 mm clearance to prevent debris falling into the motor. The clearance applies to both new and existing insulation.
Passive vents		Cover or 200 mm	See 6.2.13 for instructions. Cover the vent with a sheet of plastic and lay insulation over the plastic. The plastic sheet shall be taped or to be at least three times the size of the vent. Otherwise leave a 200 mm clearance. Vents are normally found in old houses, above showers or in hallways.



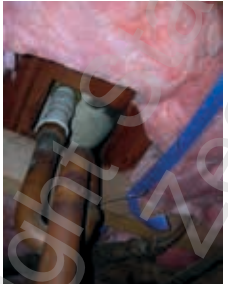


Table A1 – Clearances in the ceiling (continued)

Area	Views: external, from within ceiling, and/or label	Minimum insulation clearance	Comments
Metal chimneys and flues		75 mm	See 6.2.14 for instructions. The clearance is from the outer edge of the flue or chimney to both new and existing insulation.
Brickwork chimneys		50 mm	See 6.2.14 for instructions. The clearance is from the outer edge of a brick chimney to both new and existing insulation.
Roofing material/ underlay		25 mm	See 6.2.10 for instructions. The clearance is from the underside of the roofing/flexible underlay to the insulation.
Top plate		At least 50% top plate coverage	See section 6 for instructions. Fit insulation at least halfway over the top plates of exterior walls.

Where the appliance manufacturer's instructions are not known, use the clearances in Table A2. Do not exceed these minimum clearances by more than 50 mm wherever practicable.

**Table A2 – Clearances in the underfloor space**

Area	View from below	Minimum insulation clearance	Comments
Luminaire mounted on the SIDE of the floor joist		200 mm	See 4.2 for instructions. The clearance applies in all directions to ALL insulation and strapping, from any part of the fitting or bulb. This includes fluorescent tube lights.
Luminaire mounted on the BOTTOM of the floor joist		200 mm	See 4.3 for instructions. The clearance applies in all directions to ALL insulation and strapping, from any part of the fitting or bulb. This includes fluorescent tube lights.
Plumbing penetrations through floor		100 mm	See 7.2.4 for instructions. The clearance applies to ALL insulation and strapping, from the outer edge of where the fitting or pipe penetrates the floor. This includes ALL types of pipes.

## APPENDIX B – HEALTH AND SAFETY

(Informative)

### B1 Introduction

Appendix B is included as an informative section to this standard to provide general guidance on health and safety when installing insulation.

The Health and Safety at Work Act came into force on 4 April 2016. WorkSafe New Zealand's website, ([www.business.govt.nz/worksafe/hswa](http://www.business.govt.nz/worksafe/hswa), retrieved on 12 August 2016) provides further details of this legislation, including when the Health and Safety at Work Act is applicable. WorkSafe New Zealand's website also includes construction sector resources and general advice about how to assess and manage risk to keep yourself and others safe. These are likely to be useful for all people installing insulation, whether or not they are covered by the Health and Safety at Work Act.

The health and safety of all involved in or affected by the installation of insulation is vital.

This informative appendix provides some recommended precautions when installing insulation products, including common risks encountered. It is not sufficient on its own to ensure compliance with the Health and Safety at Work Act and does not negate the responsibility of persons conducting a business or undertaking (PCBUs) or other duty holders under the Act to understand and fulfil those duties. Nor is it definitive. Each installation setting is unique and will require an individual site-specific risk assessment to determine the necessary controls to ensure the continued health and safety of those concerned.

### B2 Site-specific risk assessment

The completion of a site-specific risk assessment prior to commencing work will assist those installing insulation to ensure the continued health and safety of themselves and others that could be affected by the work they do. It is imperative that risks are identified and assessed, and steps taken to manage them, before the installation of any type of insulation product.

Installers should involve all those potentially involved or affected by the work (including occupants, PCBUs and other workers where these duty holders exist in the circumstances) when identifying, assessing and managing risks, and should think about:

- (a) The entire building/site, not just the area where insulation is being installed; and
- (b) Work processes, including both business-as-usual activities and situations that are not considered business as usual (for example, emergencies).

Risks should be eliminated so far as is reasonably practicable. If a risk can't be eliminated, it should be minimised so far as is reasonably practicable. More information and advice about risk management can be found on WorkSafe New Zealand's website.

## **B3 Installation types**

### **B3.1 General**

The following information covers common scenarios and risks that may be encountered in insulation installation activities, and considerations when managing them.

### **B3.2 Buildings with existing foil insulation**

In buildings with existing foil insulation follow NZECP 55 when inspecting, installing, or removing insulation. This is a new code of practice developed under the Electricity Act. It describes good practice that will enable building owners and industry to manage electrical safety risks associated with working in the presence of foil insulation. Any work undertaken in the presence of foil insulation could pose electrocution risks and should only be undertaken with the power turned off.

### **B3.3 Inspecting, retrofitting and removing insulation in existing buildings**

#### **B3.3.1 General**

In existing buildings, every situation will be different and will involve different components of installation. Risks may vary depending on the building's standard of maintenance, amount of clutter, ease of access, and lighting.

A typical installation site would include inspecting and insulating ceiling and underfloor areas.

#### **B3.3.2 Inspecting and retrofitting ceiling insulation**

Ceilings are generally dark, dusty, and fragile, and in many instances low or cramped. The risks in each ceiling are seldom the same, due in part to the design and pitch of the roof, type of ceiling, presence of other installations (such as ventilation systems and TV aerials), and the external environment. Electric shock (from exposed wiring or from cutting into or stapling through electrical cabling), dust, hazardous dust inhalation, cuts, heat exhaustion, and impact injuries shall be considered together with the obvious risk of access in and around a fragile ceiling structure which is often relatively easy to fall through.

#### **B3.3.3 Inspecting and retrofitting underfloor insulation and on-ground vapour barriers**

Inspecting and installing underfloor insulation involves further interaction between the installer and the structure of the building. Encountered spaces may be dark, low, and often damp. Installers will encounter services such as electricity, gas, water, sewage, data, TV, and telephones. The work area is often cramped and includes hazards such as hazardous dust and dirt, spiders, old building materials, glass, nails, mould, animal faeces, and stagnant water. In locations with geothermal activity, toxic geothermal gases can collect under houses – check with the local council for high-risk areas.

The practice of stapling insulation to the underfloor structure introduces the risk of electric shock or electrocution. This appendix discusses this risk and provides some common-sense measures to help manage this risk. These recommendations are of a general nature.

**B3.3.4 Inspecting and retrofitting wall insulation**

Inspecting and retrofitting wall insulation includes hazards such as hazardous dust and dirt, old building materials, nails, mould, and risks of electric shock from exposed wiring. Walls can generally be insulated with ease from the floor of the building.

Sometimes higher-than-normal areas may require the use of a stable platform. Ladders should not be used as an installation platform.

**B3.3.5 Hot water cylinder wraps**

Installing foil-backed cylinder wraps around hot water cylinders adds risks associated with introducing an electrically conducting surface around electrical fittings. This significant risk requires careful installation to prevent it from inadvertently becoming electrically 'live'. The location of the cylinder would also contribute largely to other risks associated with the installation.

**B3.4 New build installations**

**B3.4.1 General**

The building industry has numerous inherent risks. Every building site should have a way of conveying information about risks on the site, for example via a hazard board, safety briefings or toolbox talks. All installers entering a new build site should conduct their own site-specific risk assessment process, before the commencement of work.

Double-volume areas over stairwells may require scaffold or secure platforms to allow installation access. These work platforms should be installed by a suitably skilled or qualified person.

**B3.4.2 New build ceiling insulation**

Most installations are conducted from below the ceiling grid, resulting in the installers looking upwards most of the time. Hence the access and general housekeeping on the site should be of a sufficient standard to allow unobstructed movement. As the work area is overhead, exposure to hazardous dust falling is to be expected and should be considered a significant risk.

**B3.4.3 New build wall insulation**

Walls can generally be insulated with ease from the floor of the building. Sometimes higher-than-normal areas may require the use of a stable platform.

**B4 Installation equipment**

**B4.1 Basic gear for the installer**

The surroundings, environment, and installation processes on retrofit and new-build sites will differ, creating the need for different tools and equipment. A general list of tools and equipment that an insulation installer may require on an installation job is given in Table B1. This is not a definitive list but a typical basic starter kit. It also excludes personal protective equipment (PPE), which is given in Table B2.

**Table B1 – Basic list of gear for insulation installers**

Available to each installer	New build	Retrofit	Available to team	New build	Retrofit
Head torch	–	Yes	Ladder	Yes	Yes
Cutting knife and blades	Yes	Yes	Drop sheet	–	Yes
Staple gun and staples	Yes	Yes	Stable working platform	Yes	Yes
Hand torch	–	Yes	Hammer	Yes	Yes
Install stick	–	Yes	Short planks (crawl support)	–	Yes
			Light	–	Yes
			Extension lead	–	Yes
			Cutting board	Yes	–
			Tape measure	Yes	Yes
			Voltage/Current tester	–	Yes

**B4.2 Personal protective equipment (PPE) for the installer**

The risks and conditions on all retrofit and new build sites will differ. As a first step, risks should be eliminated so far as is reasonably practicable. If a risk can't be eliminated, it should be minimised so far as is reasonably practicable. PPE should only be used to minimise risk when other control measures (such as substitution, isolation, engineering controls, or administrative controls) can't adequately minimise the risk. PPE should not be the first or only control considered. Typical PPE is shown in Table B2.

**Table B2 – Installer's personal protective equipment**












Items	Item description
 Cellular phone	Each team should have access to communication both in an emergency and in the normal day-to-day operations. A reliable mobile phone in a durable case, with texting and camera capabilities, is recommended.
 Hard hat	Hard hats are required in some circumstances, for example if hazard signs or boards on construction sites indicate their necessity. It is usual that when installers are required on site that these PPE items are not required but they should have them available if overhead hazards are present. Bump caps may be suitable for retrofit jobs.
 Hearing protection	Ear plugs or ear muffs are required where noise is a risk to health and safety. Industrial noise is a major factor in partial or permanent hearing loss. The danger can be lessened through the use of appropriate ear protection.
 Respiratory protective equipment	A respirator is a device designed to protect you from inhaling airborne contaminants such as harmful dusts, fibres, fumes, vapours, and gases. An air-purifying respirator with replaceable filter cartridges is advised when hazardous dust is present. Seek advice from your equipment provider on the correct type of equipment for the risks, and ensure that each person carrying out the work has equipment that fits them properly. Male users should be clean shaven to ensure correct fit.  AS/NZZ 1715 and AS/NZZ 1716 provide quality standards on respiratory protective equipment and guidance on their selection, use and maintenance. In all cases respiratory protective equipment should be certified and users trained in its use.

Table B2 – Installer’s personal protective equipment (continued)

Items		Item description
	Safety boots	Non-slip footwear should be worn when working at height. Rubber-soled shoes can reduce the severity of electric shock. Steel-toe boots may be required on building sites. Comfortable soft-soled shoes which provide grip and flexibility, and all-round protection from sharp objects such as nails, are suitable for retrofit work in ceilings.
	Eye protection	Eye protection should be fit for the purpose and job and to be worn where potential damage to the eyes could occur, for example, when installing products overhead or where health and safety signage specifies that eye protection is to be worn. Goggles or glasses may be used.
	Gloves	Gloves prevent hands from being cut or damaged by sharp objects or prevent hazardous substances from entering your body through hand contact. Rubber gloves can reduce the severity of electric shock. Non-slip surfaces help when handling bales of product.
	Protective clothing	Overalls and other protective clothing should completely cover arms and legs and protect from insect bites and skin irritants. They are used to keep contaminants from soiling clothes and from being carried from the workplace. Lightweight, disposable nylon protective clothing is best suited for retrofit ceilings and more durable polycotton protective clothing would be more suitable for underfloor work. See Figure B1.
	Hi-viz	High visibility clothing and vests help you to be seen by others. You need to wear the correct type of vest to suit the lighting conditions (day or night or day/night). This type of clothing may be required on some building sites.
	RCD unit and electrical tagging	<p>All electrical appliances and supply cords should be inspected before use. If a test and tag regime in accordance with AS/NZS 3760 is in operation the tag shall be current.</p> <p>It is good practice for all electrical appliances, leads and temporary lighting to be supplied power through portable residual current devices (RCD). Carry a voltmeter to check if items are live. Consider isolating the power supply to live cables. If this is not reasonably practicable, use hazard stickers to identify live cables.</p>
	First aid kit and fire extinguisher	Every worksite or work vehicle should have a suitably stocked first aid kit and a fire extinguisher. It is suggested that each installer has his or her own personal first aid kit as part of their gear.
	Safety harnesses and fall arrest	Working at heights requires specialist PPE and specialist training. Temporary anchorage points, static lines, shock-absorbing lanyards and full-body harnesses may be required. This equipment should comply with relevant standards and should be checked carefully for wear and faults before each use.
NOTE – Some symbols reproduced from ISO standards. Copyright remains with the International Organization for Standardization.		






Retrofit ceiling PPE	Retrofit underfloor PPE	New build PPE
		
Bump cap Air-purifying respirator Nylon protective clothing Cut-resistant gloves Knee pads Light enclosed shoes	Bump cap Goggles Dust mask Polycotton protective clothing Cut-resistant gloves Knee pads Rubber-soled boots	Hard hat Goggles Dust mask Polycotton protective clothing Hi-viz vest Cut-resistant gloves Safety boots

Figure B1 – Typical personal protective equipment (PPE)

## B5 General health and safety precautions

There are a number of health and safety risks that are common to all the insulation installation scenarios covered by B3 of this appendix. Some of the typical generic risks and possible controls are covered in Table B3, while the installation-specific risks are covered in B2 and B6 to B9 of this appendix. A risk assessment should consider other possible risks and other possible controls, in addition to those suggested here.

Table B3 – General installation health and safety risks

	Risk identified	Details	Possible controls
1.	Damaged or poorly lit access	Could lead to injuries resulting from trips and falls.	<ul style="list-style-type: none"> <li>(a) Enough portable lighting to carry out the installation in safety;</li> <li>(b) Use of rechargeable LED lighting is recommended.</li> </ul>
2.	Dust inhalation and respiratory irritants	<p>Dusts are a range of materials of respirable and inhalable particle size. Dusts are both a respiratory health hazard and skin irritant and exposure to them is likely when installing insulation. It is the small sized particles that are particularly hazardous from an inhalation perspective. People who experience asthma or any other respiratory illness may be particularly affected.</p> <p>Dust exposure may lead to asthma attacks, other breathing difficulties, or cancer.</p> <p>Crystalline respirable silica dust is created when bricks are cut by power saws during brick installation. Crystalline respirable silica dust is a carcinogen and represents a serious and potentially fatal health threat.</p> <p>Dust generated by opening insulation bags is also considered a health threat.</p>	<ul style="list-style-type: none"> <li>(a) Consider how dust exposure can be eliminated or minimised: for example, disturbing and cutting as little product as possible will reduce exposure to dusts;</li> <li>(b) Where there is heavy contamination of dust, then vacuuming the area should be considered, using appropriate industrial equipment with suitable filters attached;</li> <li>(c) Avoid opening insulation bags in homes to avoid the distribution of potentially hazardous dust;</li> <li>(d) Sources of exposure can be both new and old product so it is important to cover as much skin as possible and protect those in the vicinity from the dusts;</li> <li>(e) Wear protective clothing and suitable respiratory protective equipment in addition to other controls used to minimise exposure. Make sure you select the right respiratory protective equipment for the job, for example, by consulting your equipment provider or standard AS/NZS 1715.</li> </ul>
3.	Damaged or faulty tools and equipment	Poor storage and maintenance of equipment may lead to faulty tools that do not operate properly, causing accidents or injury.	<ul style="list-style-type: none"> <li>(a) Conduct regular equipment checks;</li> <li>(b) Ensure the check includes ladders, electrical goods, personal protective equipment (PPE), first aid kits, and mobile phones;</li> <li>(c) All electrical tools and cables should be inspected before use. If damaged they should not be used;</li> <li>(d) All electrical tools and supply cords should be plugged into a residual current device (RCD);</li> <li>(e) Problems identified with any equipment should be recorded on the site-specific hazard assessment as new or potential hazards that need to be addressed;</li> <li>(f) Keep equipment in good order.</li> </ul>

	Risk identified	Details	Possible controls
4.	Working alone	Times may arise when there is only one installer in an area due to circumstance or locality. Working alone could be dangerous if the worker has an accident or mishap and requires urgent assistance.	<ul style="list-style-type: none"> <li>(a) Wherever possible DO NOT WORK ALONE;</li> <li>(b) Ensure colleagues are aware of each other's whereabouts;</li> <li>(c) Ensure there is a system of work that includes effective communication. A mobile phone is an essential safety device to call or text for assistance. Be aware that many areas lack adequate reception coverage;</li> <li>(d) Two-way radios could be used;</li> <li>(e) Relying on home occupants or site offices is not recommended;</li> <li>(f) Always be aware of the risks involved should an emergency arise.</li> </ul>
5.	On-site violence and aggression	May result in stress or physical injury.	<ul style="list-style-type: none"> <li>(a) Ensure good and frequent communication with team members and supervisors;</li> <li>(b) Briefing the retrofit dwelling's building owner is important and the installer should ask the owner if they have any specific requirements or customs which they would like to be upheld;</li> <li>(c) Should reasonable negotiations fail, the installer is to inform the building owner of their company's complaints procedure, make the site safe and leave until the situation can be resolved;</li> <li>(d) In extreme cases, call the police for assistance.</li> </ul> <p>NEVER PUT YOURSELF INTO A RISK SITUATION.</p>
6.	Dogs	Dogs could bite or attack, causing injury or further health complications.	Ensure dogs and other potentially disruptive animals are locked up or restrained, before entering the property.



Table B3 – General installation health and safety risks (continued)

	Risk identified	Details	Possible controls
7.	Falling from heights	Impact injury or even death can result from falling from work platforms, trestles, ladders, or scaffolding.	<ul style="list-style-type: none"> <li>(a) Work environments will vary and may require working from platforms or scaffold;</li> <li>(b) Ensure that correct personal protective equipment (PPE) is worn, correct training in the use of or moving of scaffold has been given and that installers have received the correct safety training for working at heights;</li> <li>(c) If workers can sustain a fall from height (this includes working on flat roofs), fall protection, such as scaffolding, edge protection safety harness, safety net, should be used;</li> <li>(d) All scaffolding, temporary structures, planks, decking, tools, and equipment need to be secured to stop them from falling;</li> <li>(e) Make certain that people below are protected from falling objects;</li> <li>(f) Ensure ladders are used correctly (for example, set up at 1:4 base-to-height ratio, used only to three rungs from the top, placed on a solid, level surface for support, safe carrying of tools, ascending and descending with both hands), and you wear non-slip footwear;</li> <li>(g) Ladders should not be used as an installation platform.</li> </ul>
8.	Dropped consumables	May cause injury through cuts, penetration, puncture, or ingestion. Injuries can happen on site to clients, their children, or fellow workers, long after you have left.	Pick up all rubbish, blades, pins, and staples.

	Risk identified	Details	Possible controls
9.	Clutter obstructing access	May cause injury through trips, falls, impact, or penetration due to excessive materials or household items stored in, or lying around, the worksite. Each site is different and gaining access to the building may pose its own problems.	<ul style="list-style-type: none"> <li>(a) Once in the building the installer should pay particular attention to the routes to the installation's internal stairs, roof hatches, and underfloor entry;</li> <li>(b) Check stair treads for damage and grip. If there are damaged stairs consider whether it is safe to carry out the work until the stairs have been repaired;</li> <li>(c) Ensure walkways are clear of obstructions and that handrails, where present, are in good condition. Good housekeeping is essential;</li> <li>(d) In severe cases it may require halting the installation until the building owner or builder has created a safe and clear working environment.</li> </ul>
10.	Loading and offloading	May cause injury by strain or impact during handling procedures, either due to technique, location, or traffic.	<ul style="list-style-type: none"> <li>(a) Where possible choose lighter materials or those packaged in units of a manageable weight;</li> <li>(b) Survey the site first and plan how to load and unload products;</li> <li>(c) Where there are manual handling (load handling) hazards present, reduce the risk by using mechanical aids or work in pairs to stabilise loads.</li> </ul>
11.	Sharp objects	Could cause disease or infection through cuts, penetration or puncture by sharp objects such as broken glass, protruding nails, wood splinters, and needles. Tetanus is a disease carried in the gut of some animals and is easily transferred to sharp objects (nails, glass, tiles) through animal urine and faeces.	<ul style="list-style-type: none"> <li>(a) Check the work area for objects that could cause cuts and either remove them or make them safe before work commences;</li> <li>(b) If an installer receives a cut or puncture wound they should seek medical advice about the appropriate inoculation;</li> <li>(c) It is recommended that all installers have their tetanus immunisations up to date;</li> <li>(d) The most effective method to deal with a single nail is to flatten it using a hammer, taking care not to strike any cables;</li> <li>(e) Where possible, the installer should wear a hat (preferably a bump cap – baseball-type cap with a rigid plastic liner) to protect their head. Suitable protective footwear should be worn at all times – for example flexible shoes when working in the ceiling and steel-toe boots on a new build or commercial site.</li> </ul>



Table B3 – General installation health and safety risks (continued)

	Risk identified	Details	Possible controls
12.	Asbestos	<p>Once asbestos-containing materials are disturbed, tiny asbestos fibres may be released. These fibres are hazardous, and if breathed in can cause lung disease and cancer. The time between exposure to asbestos and development of disease can be 20 years or more.</p> <p>The use of asbestos in building materials and pipework insulation is no longer permitted within New Zealand; however, it may still be present in materials such as pipework insulation, roofing and cladding materials, and ceiling linings. Any building built before 1 January 2000 is likely to contain asbestos and it is still possible for more recently constructed buildings to contain asbestos. Without laboratory testing it is impossible to be certain of the presence of asbestos.</p> <p>Asbestos can be in places that you might not expect, so you could come into contact with it without knowing about it beforehand.</p>	<p>Check first if asbestos may be present in the building, for example, by asking the client or building owner. If you suspect asbestos is present:</p> <ul style="list-style-type: none"> <li>(a) Stop work immediately;</li> <li>(b) Keep people away;</li> <li>(c) Minimise the spread of contamination to other areas;</li> <li>(d) Inform your supervisor;</li> <li>(e) Inform the client, builder, or owner;</li> <li>(f) Get advice on what to do next;</li> </ul> <p>The Health and Safety at Work (Asbestos) Regulations control work which involves asbestos.</p> <p>WorkSafe New Zealand’s web resources identify likely places asbestos could be found, and what you should know about working with asbestos. See for example <a href="http://www.business.govt.nz/worksafe/information-guidance/guidance-by-hazard-type/asbestos/working-with-asbestos/tools-and-resources">www.business.govt.nz/worksafe/information-guidance/guidance-by-hazard-type/asbestos/working-with-asbestos/tools-and-resources</a> (retrieved on 17 August 2016).</p>

## B6 Ceiling insulation health and safety precautions

When inspecting, installing, or removing ceiling insulation, consider the common risks and possible controls in Table B4.

**Table B4 – Ceiling installation health and safety hazards**

	Risk	Details	Possible controls
1.	Falls through ceilings (retrofit)	Cuts, lacerations, breaks, or impact injury may be caused by falling through ceiling materials or landing on objects below.	<ul style="list-style-type: none"> <li>(a) Identify the type of ceiling and take precautionary steps to avoid damage and potential injury;</li> <li>(b) Ensure your body weight is supported by joists at all times and not by the ceiling battens;</li> <li>(c) Wear soft shoes for better feel and grip;</li> <li>(d) Identify obstacles and use adequate lighting;</li> <li>(e) Use handholds on the trusses as much as possible;</li> <li>(f) Spread your body weight and use planks or similar supports to bridge between joists if necessary;</li> <li>(g) Props may be used from below to strengthen and reinforce wide spans of ceiling.</li> </ul>
2.	Heat exhaustion or heat stroke	<p>Heat exhaustion – injury due to blurred vision, clumsiness, dizziness, or fainting.</p> <p>Heat stroke – injury due to bizarre behaviour, convulsions, or collapse.</p>	<ul style="list-style-type: none"> <li>(a) Carry out installation work in the ceiling at the beginning or end of the day to avoid midday heat. When the temperature outside is 25°C, it may be as much as 40°C in the ceiling cavity;</li> <li>(b) Take plenty of fluids before, during, and after the ceiling installation as heat exhaustion can still occur after exposure to prolonged periods of heat;</li> <li>(c) Specify the use of respirators that are fitted with exhaust valves to reduce heat build-up;</li> <li>(d) Get relief from the heat by taking breaks and drinking plenty of water to avoid dehydration;</li> <li>(e) Learn to recognise the signs of heat stress such as headaches, dizziness, fainting, irritability, confusion, thirst, nausea, and vomiting;</li> <li>(f) DO NOT DISCARD PPE to keep cool.</li> </ul>

Table B4 – Ceiling installation health and safety hazards (continued)

	Risk	Details	Possible controls
3.	Electricity (in ceiling)	The primary risk from an electric shock is serious injury or death. The second is damage to electrical supplies to the residence.	<ul style="list-style-type: none"> <li>(a) Work in the ceiling does not, as a standard practice, involve stapling but can include the cutting of all types of insulation;</li> <li>(b) Moving cables during the installation of ceiling insulation increases the likelihood of damaging the sheath and exposing the installer to 'live' wires;</li> <li>(c) Search for wires with damaged sheaths, treating those identified as 'live' and dangerous;</li> <li>(d) If necessary, STOP the installation until a licensed electrician has made the wiring safe.</li> </ul>
4.	Wasps and bees	Stings can be an irritant to most, but to those who are allergic to them they can cause anaphylactic shock and in severe cases may require urgent hospital treatment. Further unrelated hazards could be imposed on those trying to evade stinging insects or to those under the influence of anaphylactic shock.	<ul style="list-style-type: none"> <li>(a) Investigate the worksite to identify any nests or hives;</li> <li>(b) On retrofit jobs, the first person to gain access to the loft should do so making as little noise or vibration as possible;</li> <li>(c) Shine a torch beam down the inside of the eaves, the apex of the roof and the lower edges to identify any nests;</li> <li>(d) If nests are identified, work should not commence until they have been removed by a pest controller.</li> </ul>



## B7 Underfloor insulation – health and safety precautions

When inspecting, installing, or removing underfloor insulation, consider the common risks and possible controls in Table B5.

**Table B5 – Underfloor installation health and safety hazards**


	Risk	Details	Possible controls
1.	Electricity	<p>The most significant risk to be managed during underfloor installations is exposure to electricity resulting in electrical shock or electrocution. This could be in the form of exposed wires or through accidentally puncturing through the sheath of a cable while stapling. Wiring could be old, hidden, or damaged.</p> <p>Foil insulation poses a number of electrical safety risks for installers, service workers, building owners and others should they come into contact with these membranes at any stage during life of the house.</p>	<p>Installers are to ensure the power is 'OFF' before commencing installing insulation. Ensure all of the reasonably practicable steps to eliminate risks to safety have been taken. Power 'ON' or 'OFF' is dealt with in more detail in B8.</p> <p>Where there are exposed wires, a licensed electrician will need to repair or replace them before work continues, regardless of the decision to work with power 'OFF' or 'ON'.</p> <p>NZCEP 55 is a code of practice developed under the Electricity Act. It is intended to address electrical safety and the safety risks of installing electrically conductive thermal insulation in <i>new</i> electrical installations, and when working in the presence of installed electrically conductive thermal insulation.</p>
2.	Hazardous substances	<p>The work area for underfloor insulation may have been used as a 'dumping ground' for building products, which may include containers containing unknown hazardous chemicals.</p> <p>Hazardous substances can cause serious health effects. There are requirements on duty holders under health and safety legislation to manage them safely, including storing and disposing of them safely. More information can be found on WorkSafe New Zealand's website.</p> <p>Biological hazards such as used needles may result in transmitted disease, blood-borne viruses, illness, or infection.</p>	<p>(a) Provide adequate lighting during both the pre-installation inspection and while installing to identify any hazards;</p> <p>(b) If unsure what a substance is and concerned it could be hazardous, stay away from it, and seek further advice;</p> <p>(c) Some hazardous substances may be identified by a pictogram on a label, for example:</p> <div style="text-align: center;">  </div> <p>(d) Talk with the building owner or landlord to help identify the substance if possible, and to agree how the work area will be made safe.</p>

Table B5 – Underfloor installation health and safety hazards (continued)

	Risk	Details	Possible controls
3.	Mould and fungus	Underfloor installations are likely to be in areas where the surrounding ground has been damp for a prolonged period of time providing ideal conditions to support the growth of mould and fungi with potential for respiratory diseases and chest infections.	<ul style="list-style-type: none"> <li>(a) Good lighting will assist the installers in making a thorough visual inspection before they commence work;</li> <li>(b) Consider whether mould and fungus that is discovered needs to be safely removed;</li> <li>(c) Site conditions may warrant the use of respiratory protective equipment, while others may warrant the installation of a full on-ground vapour barrier before installing underfloor insulation – see section 8.</li> </ul>
4.	Leptospirosis	<p>The <i>Leptospira</i> bacteria are present in the urine of vermin like possum and rats or other infected animals. They can enter the body through cuts and cracks in the skin, through the eyes, nose, or mouth resulting in a flu-like disease.</p> <p>The disease is transmitted by both wild and domestic animals and is also often transmitted by water containing animal urine. The bacteria can remain 'live' in damp, moist conditions for several weeks.</p>	<ul style="list-style-type: none"> <li>(a) Where there is heavy contamination of the work area, then vacuuming the area should be considered, using appropriate industrial equipment with suitable filters attached;</li> <li>(b) It is important to ensure the subfloor area is dry when carrying out the underfloor insulation;</li> <li>(c) Cover all cuts and abrasions with waterproof plasters;</li> <li>(d) Personal hygiene is an important control and installers should not touch their eyes or mouth until they have completed the installation and washed their hands thoroughly.</li> </ul>
5.	Human or animal faeces	Coming into contact with human or animal faeces through broken waste pipes or underfloor animal droppings could cause disease.	<ul style="list-style-type: none"> <li>(a) Avoid contact with broken or leaking sewage or waste water pipes, as well as animal faeces;</li> <li>(b) Talk with the building owner or landlord to agree how the work area will be made clean and safe.</li> </ul>

	Risk	Details	Possible controls
6.	Cramped spaces (restricted access, elevated temperatures, poor visibility, poor air quality, claustrophobia)	<p>Cramped spaces create a risk of being trapped and of not being able to remove one's self from further harm, or being in a position where others cannot remove you from further exposure to harm.</p> <p>A 'confined space' occurs when entering an underfloor space which would not enable a person to readily escape in an emergency. This situation can arise from limited 'crawl' spaces under bearers or joists and should be avoided.</p> <p>Gas leaks under the floor can result in an explosive mixture of fuel gas and air or atmosphere that does not support life. Natural gas and LPG are odourised to have a distinctive unpleasant odour so a leak can be recognised.</p>	<p>(a) Identify all cramped spaces. The exterior of the house should be visually inspected to ensure adequate ventilation for installers;</p> <p>(b) If there is a smell of gas underfloor, the installer should withdraw until the leak has been identified and rectified by a licensed gasfitter;</p> <p>(c) If the installer determines that the crawl space is not large enough to comfortably exit (without having to exhale to reduce chest size), then the underfloor insulation should not be undertaken in this area as this will be considered a 'confined space'. 'Cap' the insulation off to the floor and record the rationale for this decision on the site-specific risk assessment;</p> <p>(d) Plan, communicate, and work in teams with a standby person outside the house;</p> <p>(e) Ensure installers are trained and competent;</p> <p>(f) Have a rescue plan in place. Can the installer be extracted or could a medic get to them if something were to go wrong?</p>
7.	Toxic geothermal gases	In locations with geothermal activity toxic geothermal gases can collect under houses.	Check with the local council for high risk areas.

## B8 Power on or power off

The power 'OFF' option is recommended and considered best practice as a means to protect installers, building owners, and others from injuries and loss of life where there is a risk of coming into contact with an electrical circuit or metal. This includes where the location of electrical conductors and metal surfaces cannot be determined.

There is no 'one size fits all' when deciding to install with the power 'ON' or 'OFF' (see Tables B6 and B7) and the decision is to be based on a house-by-house assessment for the following reasons:

- (a) Typically in the North Island there is a significant proportion of houses that have the 'mains' electrical supply entering underneath the house before joining the main switchboard, meaning the power cannot be completely isolated; and
- (b) Industry experience includes examples where building owners have 'bridged' the main switchboard between mains power and the house supply. Therefore, turning off at the main switchboard may not truly isolate the power to the house.

All reasonably practicable control measures should be used to protect the installers and building owners from electrocution.

When removing existing foil insulation, follow the power 'OFF' option described in Table B7.

**Table B6 – Installing underfloor insulation with power ON**

<b>POWER 'ON' OPTION</b>			
	<b>Steps</b>	<b>Risks/notes</b>	<b>Action</b>
1.	Provide good sources of light to carry out the installation.	Supplies to the lights may become damaged during installation and electrocute installers.	Place residual current devices (RCDs) 'in-line' to protect the installers.
2.	Identify all electrical wires and services under the house and inspect them for damage.	Damaged cable sheaths will expose the installer to an unacceptably high risk of electrocution.	If damaged sheaths are identified, stop the installation. Inform the building owner that they will need to arrange for a licensed electrician to rectify the fault before work can commence.
3.	Carry out the installation using the 50 mm isolation rule. Keep your hands, tools, and fixings at least 50 mm away from electrical wires and services at all times. Alternatively protect all electrical cables using a conduit or other suitable method to 'box' them in.	Cables and services will remain hidden when the installation has been completed.  Isolation rule (50 mm rule) relies on skilled installers following it and having a high standard of training.	Identify and tag all cables and services with the appropriate hazard warning symbol.  Using rubber-faced gloves and tools will reduce the likelihood of electrocution. However, unless they are designed to isolate the user from electricity their effectiveness cannot be relied on.
If a cable is penetrated during the installation, stop work until a licensed electrician can rectify the fault.			

**Table B7 – Installing underfloor insulation with power OFF**

<b>POWER 'OFF' OPTION</b>			
	<b>Steps</b>	<b>Risks/notes</b>	<b>Action</b>
1.	Inform building owner that power will be turned off for a given period of time.	Goods stored in building owner's fridge/freezer may spoil. Washers and dryers will need to complete their programmed cycle.	Ensure building owner is informed of this prior to the day of installation.  Ensure building owner consents to power being turned off and that occupants are not reliant on power for life-supporting/medical purposes.
2.	Identify if mains power runs under the house before entering the main switchboard or has been 'bridged'.	If mains power runs under the house it may not be practicable to disconnect the house from the supply grid by having the network company disconnect the network service fuse (for example, pole fuse).	For the portion of wiring that cannot be turned off, follow the 50 mm isolation rule for 'Power ON' in Table B6.  The location of electrical supply mains may need to be confirmed by a licensed electrician.
3.	Switch off power at the main switchboard and use lockout padlocks or place an electrical isolation tag in place.	Building owner does not understand the importance of the isolation tag.	Show them the tag as you fit it and explain that they are not to tamper with it or turn the power back on.

POWER 'OFF' OPTION			
	Steps	Risks/notes	Action
4.	Check ring circuits to ensure power is off.	Electrical installation may be old and designed on a series of 'spikes' running from the fuse box.	Double-check wiring when entering the underfloor cavity with an electrical proximity meter. The location of electrical supply mains may need to be confirmed by a licensed electrician.
5.	Ensure there is an adequate supply of light sources (torches or external generator).	Without good light the installers may be exposed to sharp objects, mould, and stagnant water which may contain <i>Leptospira</i> bacteria and other contaminants. If using a generator to power lighting or tools the combustion products constitute a hazard if not exhausted to a safe location.	Don't forget any installers that may be working in the roof space at the same time. They run the risk of falling through the ceiling. Provide spare torch batteries. Locate the generator outdoors so that the exhaust does not enter any building, underfloor space or other enclosed area.
6.	Identify the location and condition of all wires and services during the installation, inspecting them for damage.	Power 'OFF' is temporary and will be switched back on when the installation is completed. Future tradesmen will be placed at risk of electrocution if they are not visually informed of the location of hidden wires and services.	Tag all wires and services during the installation with the appropriate hazard warning symbol. If wires are found to have a damaged sheath stop the installation. A licensed electrician shall rectify the fault before proceeding.
7.	Carry out the installation using the 50 mm isolation rule. Keep your hands, tools, and fixings at least 50 mm away from electrical wires and services at all times. Alternatively protect all electrical cables using a conduit or other suitable method to 'box' them in.	Cables and services will remain hidden when the installation has been completed. Isolation rule (50 mm rule) relies on skilled installers following it and having been given a high standard of training.	Identify and tag all cables and services with the appropriate hazard warning symbol. Using rubber-faced gloves and tools will reduce the likelihood of electrocution. However, unless they are designed to isolate the user from electricity their effectiveness cannot be relied on.
8.	Complete the installation.	Wires may be stapled through during the installation.	–

## B9 Hot water cylinder health and safety precautions

When installing pipe insulation or cylinder wraps, consider the common risks and possible controls in Table B8.

**Table B8 – Hot water cylinder health and safety precautions**

	Risk	Details	Possible controls
1.	Electricity	Sometimes the sheaths protecting electrical cables to hot water cylinders will have perished over time, leaving exposed 'live' wires and the risk of electrical shock or electrocution.	<ul style="list-style-type: none"> <li>(a) Switch off the local power supply to the cylinder before inspection or installation of the cylinder wrap and label the switch as 'out of use' and 'risk of electrocution';</li> <li>(b) The condition of the protective sheath to the power supply should be inspected and a licensed electrician called to rectify any faults identified before work continues;</li> <li>(c) After fitting the wrap, remove the 'out of use' label from the local switch and turn on the power supply. Test the foil (if foil-backed wrap has been used) with a volt meter to ensure the foil is not electrically 'live' – nil result;</li> <li>(d) If the volt meter returns a positive result, switch off the power and ensure a licensed electrician rectifies any faults before the installation is completed.</li> </ul>
2.	Hot surfaces	Risk of burns directly from hot surfaces, or accidents resulting from involuntary movements due to contact with heated surfaces.	<ul style="list-style-type: none"> <li>(a) Check to see if a manual thermostat has been fitted and ensure it reads at or above 60°C (the NZBC stipulates that hot water should not be stored at less than 60°C);</li> <li>(b) If no thermostat is visible then there are no adjustments that can be made by the installer;</li> <li>(c) If accessing the cylinder to fit the wrap requires close contact with the hot surface, the installer should feel the cylinder with the back of their hand to ensure it doesn't feel uncomfortably hot;</li> <li>(d) If the cylinder feels too hot and an adjustment cannot be made, switch off the local power supply to the cylinder and drain some of the hot water from the cylinder through a hot water tap in the house. This will allow the cylinder to cool down to a comfortable (test again) temperature;</li> <li>(e) This precaution also applies to insulating hot pipes where contact is unavoidable.</li> </ul>

## APPENDIX C – WARNING SIGN

(Informative)

Where insulation is installed in an accessible roof space around recessed luminaires that require clearances between the insulation and the recessed luminaire, a permanent and legible warning sign should be installed in the roof space adjacent to the access hatch, in a position that is visible to a person entering the space. The sign shall contain the words shown in Figure C1 with a minimum size of lettering of 10 mm.

This page may be reproduced for installation on site.



Figure C1 – Warning sign

## APPENDIX D – CLIMATE ZONES

(Informative)

The climate zone boundaries are based on climatic data taking into consideration territorial authority boundaries, providing for three zones (see Figure D1).

Zone 1 comprises the Thames-Coromandel District, the Auckland District and all districts north of these, and all offshore islands north of 37° 15' south.

Zone 2 comprises all of the North Island excluding Zone 1, the Taupo District, the Ruapehu District, and that part of the Rangitikei District north of 39° 50' south.

Zone 3 comprises the Taupo District, the Ruapehu District, that part of the Rangitikei District north of 39° 50' south, the South Island, Stewart Island, the Chatham Islands, and all offshore islands not in Zone 1.

The latitude of 39° 50' south lies just south of Mangaweka. Mangaweka is in Zone 3, while Ohingaiti is in Zone 2.

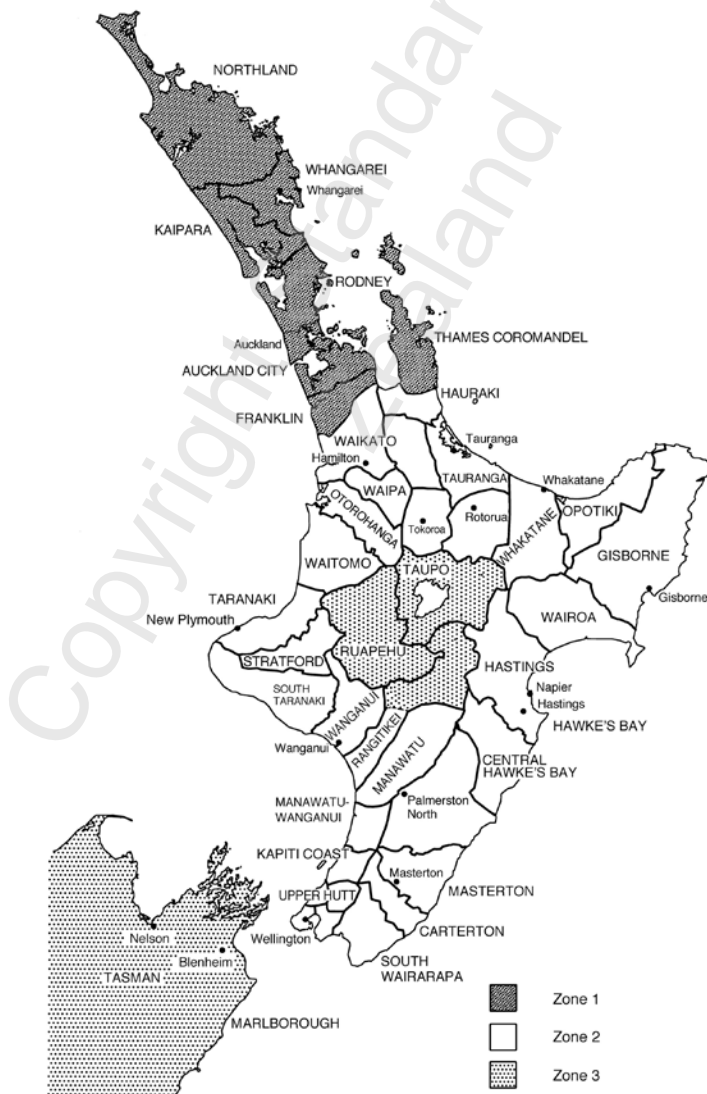


Figure D1 – New Zealand climate zones (reproduced from NZS 4218)



Copyright Standards New  
Zealand

---

**© 2016 NEW ZEALAND STANDARDS EXECUTIVE**

Approved by the New Zealand Standards Approval Board on 17 August 2016 to be a New Zealand Standard pursuant to section 12 of the Standards and Accreditation Act 2015.

First published: 30 August 2016

The following references relate to this standard:

Project No. P4246

Draft for comment No. DZ 4246

Typeset by: Standards New Zealand

---

